



Hardware Manual

TSD80 / TSD130 Revisions 1, 2, and 3



Keep all manuals belonging to this product during its life span. Pass all manuals to future owners and users of this product. This English version is the original version of the product manual.

Document HWTSD80-TSD130_0-3_HardwareManual_EP
Version 004
Source Q:\Doc\Hardware\HWTSD\TSD80-TSD130\Rev0-3\HWTSD80-TSD130_HardwareManual\
Destination T:\doc\Hardware
Owner up

Copyright © 2017
Triamec Motion AG
All rights reserved.

Triamec Motion AG
Industriestrasse 49
6300 Zug / Switzerland

Phone +41 41 747 4040
Email info@triamec.com
Web www.triamec.com

Disclaimer

This document is delivered subject to the following conditions and restrictions:

- This document contains proprietary information belonging to Triamec Motion AG. Such information is supplied solely for the purpose of assisting users of Triamec products.
- The text and graphics included in this manual are for the purpose of illustration and reference only. The specifications on which they are based are subject to change without notice.
- Information in this document is subject to change without notice.

Contents

1	General.....	4
1.1	Target group.....	4
1.2	Standards used.....	4
1.3	Abbreviations.....	5
1.4	Symbols used.....	5
2	Safety.....	6
2.1	Intended use.....	7
2.2	Prohibited use.....	7
2.3	Responsibility.....	7
2.4	CE conformance and Declaration of conformity.....	8
3	Ordering.....	9
3.1	Ordering guide.....	9
3.2	Accessories.....	9
4	Handling.....	10
4.1	Nameplate.....	10
4.2	Transport.....	10
4.3	Storage.....	11
4.4	Packaging.....	11
4.5	Disassembling.....	11
4.6	Maintenance, Cleaning and Repair.....	12
4.7	Disposal.....	12
5	Technical description.....	13
5.1	General features.....	13
5.2	Electrical Specifications.....	14
5.2.1	General.....	14
5.2.2	Rated currents.....	16
5.2.3	EMC and Motor properties.....	16
5.2.4	Protective Earthing conductor current.....	17
5.3	Motor brake.....	17
5.4	Dynamic braking.....	17
5.5	Safety Function STO.....	18
5.5.1	Typical use.....	18
5.5.2	Commissioning.....	18
5.5.3	Functional Description.....	18
5.5.4	Safety characteristic data.....	19
5.5.5	Prohibited Use.....	20
5.6	Mechanical specifications.....	20
5.7	Ambient and mounting conditions.....	21
6	Mechanical Installation.....	22
6.1	Safety Instructions.....	22
6.2	Guide to mechanical installation.....	23
7	Electrical Installation.....	24
7.1	Safety Instructions.....	24
7.2	Guide to electrical installation.....	25

7.3	Overview of Drive Connections.....	26
7.4	Electrical supplies.....	28
7.4.1	24V Logic supply (X2).....	28
7.4.2	DC-Bus (X1).....	29
7.5	STO (X3+X4).....	30
7.6	Field-bus connection (X5, X6).....	31
7.7	Option Modules (X10, X11).....	32
7.8	Feedback Systems (X20, X21).....	33
7.8.1	Analog Sin/Cos Encoder with Index.....	34
7.8.2	Analog Encoder with EnDat.....	35
7.8.3	Encoder with EnDat 2.2.....	36
7.8.4	Incremental RS422 Encoder with Index.....	37
7.8.5	Incremental TTL Encoder with Index.....	38
7.8.6	TTL Inputs Connection.....	39
7.9	Digital inputs and outputs (X30+X31).....	40
7.9.1	Digital inputs.....	40
7.9.2	Digital Outputs.....	41
7.9.3	Motor-Holding brake.....	41
7.10	Motor connection (X40+X41).....	42
7.10.1	Motor Power Connection.....	42
7.10.2	Motor temperature.....	44
8	Commissioning and Diagnostics.....	45
9	Appendix.....	46
9.1	Warranty Information.....	46
9.2	Service.....	46
	References.....	46
	Revision History.....	47



During operation there are hazards, with the possibility of death, serious injury or material damage. The operator must ensure that the safety instructions in this manual are followed and that all personnel responsible for working with the drive have read and understood the product manual.



1 General

Dear user!

This manual describes the TSD80/TSD130 series of Triamec digital servo drives. In order to be able to start operation of your Triamec drive quickly without problems, we suggest you to read this manual before carrying out any operation with the Triamec hardware.

Technical data, dimensional drawings and more background information can be found at www.triamec.com

1.1 Target group

This manual addresses persons with the following qualifications:

Transport : only persons which know how to handle electrostatically sensitive components.

Installation : only electrically qualified personnel.

Setup : only persons with electrical engineering and drive technology qualifications. The qualified personnel must know and observe the following standards:
IEC 60364 and IEC 60664 national accident prevention regulations.

1.2 Standards used

Standard	Content
EN ISO 13849-1:2008	Safety of machinery: Safety-related parts of control systems
IEC 60204	Safety of Machinery: Electrical equipment of machinery
IEC 60364	Low-voltage electrical installations
EN 60529:1991	Protection categories by housing (IP Code)
IEC 60664-1:2007	Insulation coordination for equipment within low-voltage systems
IEC 60721-3-2:1997 IEC 60721-3-3:2002	Classification of environmental conditions
IEC 61326-3-1:2008	Immunity Requirements for safety-related systems
IEC 61508:2010	Functional safety of electrical/ electronic/ programmable electronic safety-related systems
IEC 61800 EN 61800-1:1999 EN 61800-3:2012 EN 61800-5-1:2008 EN 61800-5-2:2008	Adjustable speed electrical power drive systems General Requirements EMC requirements and specific test methods Safety requirements – Electrical, thermal and energy Functional Safety

Table 1: Standards.

1.3 Abbreviations

Abbrev	Meaning
CE	CE marking
EMC	Electromagnetic compatibility
FET	Field effect transistor
GND	Ground
IEC	International Electrotechnical Commission
ISO	International Organization for Standardization
LED	Light-emitting diode
PL	Performance Level
PWM	Pulse-width modulation
SIL	Safety Integrity Level
STO	Safe torque off
SVM	Space vector modulation
TM	Triamec Motion AG
VAC	AC voltage
VDC	DC voltage
VDE	Verband der Elektrotechnik, Society of German Electrical Technicians

Table 2: Abbreviations

1.4 Symbols used

The following table lists the symbols that are used in this manual. Each symbol belongs to its danger class with the risk which arises when not complying the safety instruction.





Symbol	Indication
	DANGER CAUSED BY HIGH VOLTAGE OR HIGH CURRENT! Indicates an electrical hazard situation which will result in death or serious injury, if not avoided!
	DANGER CAUSED BY ROTATING OR MOVING PARTS! Indicates a hazard situation which could result in death or serious injury, if not avoided!
	ATTENTION! Indicates a hazard situation which could result in minor or moderate injury or may cause damage to or malfunction of the hardware, if not avoided!
	NOTICE Indicates useful information or a reference to another document

Table 3: Symbols and danger classes

2 Safety

NOTICE

The user must have read and understood this manual before carrying out any operation on Triamec hardware. The safety information must be observed every time to avoid hazards and/or material damage. Triamec Motion AG disclaims all responsibility to possible industrial accidents and material damages if the procedures & safety instructions described in this manual are not followed.







Symbol	Safety Information
	During operation there are hazards, with the possibility of death, serious injury or material damage. Do not open or touch the equipment during operation. Keep all covers and cabinet doors closed during operation. Touching the equipment is allowed during installation and commissioning for properly qualified persons only.
	There is a danger of electrical arcing to electrical contacts or persons. To avoid electric arcing, never touch contacts of the drive or connect/disconnect the drive while it is operating and the power source is on.
	Contacts and cables can carry a high voltage, even when the motor is not in motion. Disconnect the drive from all voltage sources before it is disassembled for servicing. After shutting off the power and disconnecting the drive from the power supply, wait at least ten minutes before touching parts of the equipment that are normally loaded with electrical charges. Capacitors can still have dangerous voltages present up to five minutes after switching off the supply power. To be sure, measure the voltage of the DC Bus link and wait until the voltage is below 40V.
	Only properly qualified personnel are permitted to carry out activities such as transport, installation, commissioning and maintenance. Properly qualified persons are those who are familiar with the transport, assembly, installation, commissioning and operation of the product, and who have the appropriate qualifications for their job. The qualified personnel must know and observe the following standards: <ul style="list-style-type: none"> • IEC 60364 and IEC 60664 • national accident prevention regulations
	The manufacturer of the machine must produce a risk assessment for the machine and take appropriate measures to ensure that unforeseen movements do not result in personal injury or material damage.
	Servo drives may have hot surfaces during operation and some time after switching off. The Surface can reach temperatures above 80°C. Touching the surface can lead to personal injury.
NOTICE	Check the Hardware Revision Number of the product. This revision number must match the Hardware Revision Number on the cover page of this manual. Always comply with the connection conditions and technical specifications.
NOTICE	Do not touch electronic components and contacts of the drive (electrostatic discharge may destroy components). Discharge your body before touching the drive.
NOTICE	Please contact Triamec Motion AG in case of missing information or doubt regarding the installation procedures, safety or any other issue.

Table 4: Safety Information

2.1 Intended use

Servo drives are safety components for installation into stationary electric, industrial machines and commercial systems.

Safety Information	
	The manufacturer of the machine must produce a risk assessment for the machine and take appropriate measures to ensure that unforeseen movements do not result in personal injury or material damage.

Cabinet

The servo drive must only be operated in a closed control cabinet, as defined in chapter 5.7, which may also require ventilation or cooling.

Power supply

The drive must be connected to a compatible power supply. Possible devices are Triamec TP80 for TSD80 Drives and Triamec TP130 for TSD130 Drives. Power supply must be galvanically isolated from the supply mains. Connection to power supplies is described in chapter 7.4.2.

Motors

The TSD80/TS130 family of servo drives is exclusively intended for driving suitable synchronous servo-motors, asynchronous motors, voice coil and DC motors.

Safety

Observe the chapter 5.5 when you use the safety function STO.

2.2 Prohibited use

Other use than described in chapter 2.1 is not intended and can lead to injured persons or damage of equipment. The use of the servo drive in the following environments is prohibited:

- potentially explosive areas
- environments with corrosive and/or electrically conductive acids, alkaline solutions, oils, vapors, dusts

Commissioning the servo drive is prohibited if the machine in which it was installed,

- does not meet the requirements of the EC Machinery Directive
- does not comply with the EMC Directive or with the Low Voltage Directive
- does not comply with any national directives

The control of holding brakes by these servo drives alone may not be used in applications, where personnel security is to be ensured with the brake.

2.3 Responsibility

Electronic devices are never fail-safe. The company setting up and/or operating the machine or plant is itself responsible for ensuring that the drive is rendered safe if the device fails.

The standard IEC 61800-5-2 'Safety of machines' stipulates safety requirements for electrical controls. They are intended for the safety of personnel and machinery as well as for maintaining the functional capability of the machine or plant concerned, and must be observed.

The function of an emergency stop system does not necessarily cut the power supply to the drive. To protect against danger, it may be more beneficial to keep individual drives running or to initiate specific safety sequences.

2.4 CE conformance and Declaration of conformity

NOTICE This product can cause high-frequency interferences in non industrial environments. This can require measures for interference suppression like additional external EMC filters.

Conformance with the IEC 61800 is mandatory for the supply of servo drives within the European Community.

The servo drive meets the noise immunity requirements to the 2nd environmental category (industrial environment). For noise emission the drive meets the requirement to a product of the category C2 under certain conditions. More information can be found in chapter 5.2.3.

Document No: HWTSD80-TSD130_1-3_EcDeclaration_E001

EC Declaration of Conformity



We, the company

Triamec Motion AG
Industriestr. 49
CH-6300 Zug / Switzerland

hereby in sole responsibility declare the conformity of the product series
Servo Drives TSD80, TSD130 (Hardware Rev. 1 to 3)
when used with the power supply TP80 or TP130 (Hardware Rev. E)

with the following standards:

- Electromagnetic Compatibility according to EN61800-3:2004
- Electrical Safety according to EN61800-5-1:2008
- Functional Safety according to EN61800-5-2:2008 and EN ISO 13849-1:2007 and EN ISO 13849-2:2003

if used in accordance with the "Hardware Manual"

Issued By Triamec Motion AG
Zug, 12.09.2017



Urs Probst, CEO
Legally valid signature

The above-mentioned company has the following technical documentation for examination:

- Operating instructions (see "Hardware Manual" of power supply and drives)
- Setup Software
- The special technical product documentation has been created.

Responsible person for documentation: Urs Probst, Phone +41-41-747 4040

Figure 1: EC-Declaration

3 Ordering

3.1 Ordering guide

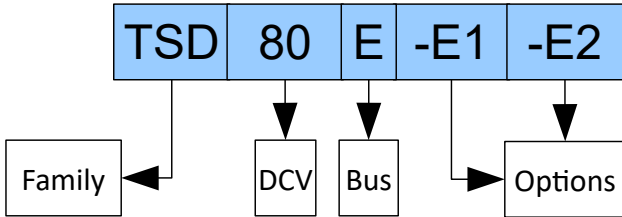

Figure 2: Example part number of a 80V TSD series drive with EtherCAT and option modules TOE1 and TOE2.

Decide from the following product variants when ordering a TSD family drive. The “D” in the family name denotes dual axis drives capable of driving two motors.

The first number (DCV) after the family name is the nominal DC-Bus voltage rating. This manual covers “80” and “130”, the 80V and 130V products.

Immediately after this number the fieldbus (Bus) is chosen, where “E” denotes EtherCAT and no character or “T” denotes “Tria-Link”.

Then up to two option modules are specified. See chapter 7.7 for the possible option modules and [6] for a detailed description. Use a “-” followed by the third and fourth letter of the option module name, e.g., for the option module TOE1 choose “-E1”. Leave the dash part away for a drive without option module, e.g. “TSD80”.

3.2 Accessories

Triamec Motion AG delivers some useful accessories for the drives. The table below shows the most helpful items. For more information contact Triamec Motion AG or visit the Triamec homepage using following address www.triamec.com.

	Product	Specification
Power Supplies	TP80	Input Voltage: 1x or 3x20...56VAC ±10%, 50/60Hz Output Voltage: rated 80VDC; max. 93V ±2%
	TP130	Input Voltage: 1x or 3x20...90VAC ±10%, 50/60Hz Output Voltage: rated 130VDC; max. 140V ±2%
Servo-Drive Accessories	STO-plug assembly	If STO is not to be used
	Motor-shield/screen management	Triamec shield connection clamp

Table 5: Triamec drive accessories.

4 Handling

4.1 Nameplate

The nameplate depicted below is attached to the side of the servo drive.



Figure 3: Nameplate of the TSD series drives.

4.2 Transport

- During transport, the drive must remain inside its original packaging which complies with the ESD standard.
- The transport conditions must respect the IEC 61800-1 standard.
- Transport by qualified personnel only.
- Avoid shocks while transporting.
- The servo drives contain electrostatic sensitive components, that can be damaged by incorrect handling. Discharge yourself before touching the servo drive. Avoid contact with highly insulating materials, such as artificial fabrics and plastic films. Place the servo drive on a conductive surface.
- If the packaging is damaged, check the unit for visible damage. In such an event, inform the shipper and the manufacturer.

TSD80, TSD130			
Temperature	-25°C (-13°F) and +70°C (+158°C), max. rate of change 20K / hour		
Humidity	less than 95% at max +40°C without condensation		
Shock limit	Dropping height of packed device max. 0.25m		
Vibration limit	Frequency	Amplitude	Acceleration
	2Hz ≤ f < 9Hz	3.5mm	not applicable
	9Hz ≤ f < 200Hz	not applicable	10m/s ²
	200Hz ≤ f < 500Hz	Not applicable	15m/s ²

Table 6: Climatic and mechanical conditions during Transport.

4.3 Storage

- During storage, the drive must remain inside its original packaging which complies with the ESD standard.
- The storage conditions must respect the IEC 61800-1 standard.

	TSD80, TSD130
Temperature	-25°C (-13°F) and +55°C (+131°F), max. rate of change 20K / hour
Humidity	between 5 and 95% without condensation
Storage duration	Less than 2 years: without restriction. More than 2 years: capacitors must be reformed before setting up and operating the drive. To do this, remove all electrical connections and apply DC for about 30 minutes to the DC-Bus terminals (J1).

Table 7: Conditions during Storage.

4.4 Packaging

Triamec drives come in a recyclable cardboard box with the following content



	TSD80, TSD130
Dimensions W x D x H	343 x 228 x 58mm ³
Labeling	label on box
Delivery content	<ul style="list-style-type: none"> ▪ Servo drive TSD80 or TSD130 ▪ Online documentation and setup software 'TAM System Explorer' on CD-ROM ▪ Mating connectors X1, X2, X3, X4, X30, X31, X40, X41

Table 8: Packaging.

Accessories must be ordered separately. A list of accessories and options can be found in chapter 3.2.

4.5 Disassembling

Observe the sequence below, if a servo drive has to be disassembled (e.g. for replacement).

	Action
	1. Switch off the power supply that supplies the drive. Wait at least ten minutes after switching off the power supply before touching potentially live sections of the equipment (e.g. contacts). To be sure, measure the voltage in the DC Bus link and wait until it has fallen below 40V. Remove the wiring. Disconnect the earth (ground) connection at last.
	2. During operation the heat sink of the servo drive may reach high temperatures. Before touching the device, check the temperature and wait until it has cooled down below 40°C (104°F).



4.6 Maintenance, Cleaning and Repair

The devices do not require any maintenance, opening the devices invalidates warranty.

Cleaning:

If the casing is dirty, clean with Isopropanol or similar. Do not immerse or spray. Dirt inside the unit must be cleaned by the manufacturer.

Repair:

Repair of the servo drive must be done by the manufacturer. Opening the devices means loss of the guarantee. Disassemble the equipment as described in chapter 4.5 and send it in the original packaging to Triamec Motion AG.

4.7 Disposal

We take old devices and accessories back for professional disposal (WEEE-2002/96/EC-Guidelines). Transport costs are the responsibility of the sender. Disassemble the equipment as described in chapter 4.5 and send it to Triamec Motion AG.

5 Technical description

The Triamec digital servo drives TSD80/TSD130 series master even the most difficult motion problems: Highly dynamic positioning tasks or on the other hand very precise motion.

This series is available for two field buses, **Tria-Link** a flexible field bus developed by Triamec, and **EtherCAT**, a standardized field bus.

The drives are equipped with state of the art dual core cortex-A9 and FPGA technology that allows controller sampling rates up to 100kHz. They do not include an integral power supply. The corresponding power supplies TP80 and TP130 are ordered separately from Triamec Motion AG.

5.1 General features

General features

- Two motor axis systems per drive.
- Standard two full featured encoder inputs, additional inputs possible with option modules.
- Sin/Cos-Encoder with auto-calibration, Incremental- or Digital Encoder supported
- Up to two option modules for additional encoders, analog inputs, and more.
- 100kHz current controller loop with space vector modulation and an advanced feed forward path.
- 100kHz position controller loop with dual PID architecture and 2*5 filter blocks per axis.
- 10kHz internal path planning reprogrammable at 10kHz.
External path planning at 10 kHz (axis coupling)
- Synchronous servomotors, linear motors DC and asynchronous motors can be used
- Standalone mode, persistent parameters and program code
- Compact dimensions

Supervision

- i²t motor and drive, over-voltage, over-current protection.
- Safety function STO (up to SIL 3, PL e)

Commissioning and Diagnostics

- Triamec TAM System Explorer

Communication

- USB, for example: observe real time 32Bit signals (80x10kHz, ... 8x100 kHz)
- Stand-alone operation

Tria-Link drives

- 200Mbps, Host(PC) and inter drive communication
- Host connection by PCI-/PCI-Express bus Card TLxxx

EtherCAT drives

- Standard EtherCAT COE slave, may be used as DC-master function.

In-Drive TAMA programming

- 100µs reaction time
- Virtual Machine (TAMA) that executes freely programmable code
- possible programming languages (Microsoft® C#/C++/J#/Visual-Basic)
- 1 real-time user program in 10kHz task
- 1 axis coupling program in 10kHz
- 1 asynchronous user program
- Stand-alone applications possible

PC programming

- Control Application on Windows PC via TAM SDK for Microsoft® .NET Framework
- Control Application on Beckhoff TwinCAT PLC with CNC or NCI
- Control Application on Linux PC via C++ Kernel driver

5.2 Electrical Specifications

5.2.1 General

		TSD80		TSD130	
Motor Configurations		DC	AC ¹	DC	AC
Rated Motor Voltage		80 VDC	55VAC	130VDC	85VAC
DC-Bus voltage range		20 – 95VDC		20 – 145VDC	
Switching frequency of output		50kHz or 100kHz		50 kHz or 100kHz	
Rated output power per axis (at 50kHz switching frequency)		0.8kW	1.1kW	1.3kW	1.7kW
Logic supply		PELV 24VDC±10% @1500mA max. Do not hot-plug Rev. 1 due to very high inrush currents. For Rev. 2 and Rev. 3 hot-plug behavior is improved.			
Temperature Supervision		Various sensors in the drive (temperature range -40°C ... 125°C), 1 external sensor per motor, supported sensor types: KTY83, KTY84, PT100, PT1000 (temperature range -40°C ... 300°C)			
Position Encoder	General	The supply delivers 5.2V and maximum 250mA and is short-circuit proof. It is connected to internal 24V and requires enforced insulation against the motor phases.			
	Analog	Sin/Cos 1Vss, 65536 times interpolation, auto calibration, 500kHz max. frequency, FIR-Filtering; Use Option TOE2 for faster analog sampling.			
	Incremental	Pulse-frequency 5MHz max., glitch- and FIR-Filtering; Standards: RS-422 or TTL			
	Digital (Serial)	Standards: EnDat 2.1/2.2 absolute pos. with analog sin/cos and (partially) EnDat 22 without analog sin/cos.			

1 AC-motors: 2 or 3 phases, synchronous or asynchronous

	TSD80	TSD130
Digital Inputs	6 Inputs per axis, isolated from the logic supply, 24V, 1200µs.	
Digital Outputs	2 isolated high-side switches per axis, 24V, 1A continuous, 2A peak. The common ground of both outputs is galvanically isolated from the logic supply. An external supply must be provided, which may be the logic supply.	
General purpose TTL in	4 TTL level digital inputs per axis	
Safe Torque Off (STO)	<p>STO inputs 1 and 2 are SPS compatible 24V logic inputs according to IEC EN61131-2, Type 1 with typical currents of 7mA@24V.</p> <p>The safe OFF-State is entered latest below $U_{Safe}^{STO} = 5V$.</p> <p>The reliable ON-State is reached above 15V.</p> <p>Process-safety time $t_{Safe}^{STO} = 50ms$, STO-inconsistent time $t_{Inconsistent}^{STO} = 50ms$</p> <p>STO-ignore time $t_{Ignore}^{STO} = 1ms$, STO-ignore rate $f_{Ignore}^{STO} = 1Hz$</p> <p>The STO Power output X3 must only be used for bridging to X4 when STO is not used.</p>	

Table 9: Technical data TSD series drives.

5.2.2 Rated currents

The maximum permissible drive output current and the peak current are dependent on the power stage switching frequency, the drive type and the ambient temperature.

All the specifications below are given for an ambient temperature ranging from +5°C (41°F) to +40°C (104°F).

	Switching frequency	Rated output current	Peak output current
TSD80	50kHz	10Arms	20A
	100kHz	7.5Arms	15A
TSD130	50kHz	10Arms	20A
	100kHz	7.5Arms	15A

Table 10: Rated and peak output current.

Overload protection on the supply side: The TPxxx power supply hardware manual demands a three phase input current protection of 20A and a maximum prospective current rating of 40 kArms. Equivalent protection must be provided if a third party power supply is used.

5.2.3 EMC and Motor properties

There are restrictions on the motor and motor cable properties depending on the PWM frequency. In the following table, capacity refers to the sum of cable capacity and motor capacity with respect to earth.

	100 kHz	ECO (50 kHz)	
Cable length	5	10	m
Capacity per axis	5	10	nF

Table 11: Permissible motor and motor cable properties.

The Hardware Manual of the power supplies (TP80 and TP130) contain

- Further restrictions on the total permissible capacity of all motors and motor cables attached to the same power supply.
- The expected EMC class according to the standard EN 61800-3 depending on these properties.

To reach these EMC requirements, proper shielding is mandatory, see chapter 7.2. Some motor properties might require a motor-side sine filter.

If a third party power supply is used, be aware that

- The EMC level reached depends strongly on the common mode filter capability of the power supply.
- The complete system must be tested for conformance with 61800-3, especially the conducted emissions part.
- Input protection circuitry must protect the Dc-Bus from external Burst and Surge events.



5.2.4 Protective Earthing conductor current

There are two 10nF Y-capacitors between DC-Bus and earth. These cause currents in the protective earth connections if the DC-Bus contains common mode components of the line frequency. The same applies due to the motor shielding capacitors discussed in chapter 5.2.3, when the motor PWM is on. These currents may extend beyond the 3.5mAAC limit of the 61800-5-1:2008 standard. Therefore a second earth connection is mandatory, see chapter 7.4.2.

5.3 Motor brake

A motor holding brake can be controlled directly by the drive. The digital output 1 or 2 switch is used for the brake functionality. See brake wiring in chapter 7.9.3. Consult [2] for the software configuration of the motor brake.

A safe break output is provided but not certified yet.

Symbol	Safety Information
 CAUTION	This function does not ensure personnel safety! Hanging loads (vertical axes) require an additional mechanical brake which must be safely operated or series connection of the safety switch in within the brake loop shown here.
 DANGER	AVOID DANGER ON POSSIBLE FAILURE Be aware that this is not a safety output. It is prohibited to use this output alone when failure might cause a dangerous situation.

5.4 Dynamic braking

During braking with the aid of the motor, energy is fed back to the drive system and the voltage of the DC-Bus may increase. Using the Triamec TP80 or TP130 supports this situation with the brake resistor in the Power supply.

Using the Triamec TP80 or TP130 power supplies, several amplifiers of the same series can be operated on a common DC bus link, without requiring any additional measures. Energy fed back by one drive is stored in the power supply capacitors. If the voltage passes the brake limit of the power supply, the internal or external brake resistor dissipates energy. If the energy to be dissipated goes beyond the brake resistor specification, this feature is turned off and the bridge voltage rises further. Then the maximum bridge voltage of the drives will be reached and the drives generate the error "BridgeVoltageOut-OfRange" and the output stage is switched off. Since the mechanics now runs without deceleration, the bridge voltage will not rise any further.

For more information see the documentation of the TP80/TP130 Power Supplies [1].

5.5 Safety Function STO

The Safe-Torque-Off (STO) feature protects personnel against unintended restarting of drives. See chapter 7.5 for connector description.

5.5.1 Typical use

A typical use case of the STO function is the integration in the safety concept of a CNC machine. The door of the critical area contains a safety switch attached to a safety device. If the door is opened, the safety device opens two relay contacts. These are wired to the STO function of the drive. With the contacts open, the two channels of the STO cut the energy to the motor leaving the drive in a safe state.

5.5.2 Commissioning

Before using the STO safety features:

- Execute a risk assessment of the equipment to confirm that the system safety conditions are met.

The following actions need to be taken during installation before using the STO safety features.

- Make sure the STO channels are connected to the external safety switch as defined during parent system design.
- Setup the drives and start communication. Enable the axis. Make sure there is no error message.
- Disconnect one STO channel from the Safety switch and check the drive state. The state must show the error "STO inconsistent".
- Connect both channels as standard, clear the error from above and Enable the axis again.
- Disconnect both channels simultaneously. The state must show "STO Active Error".
- TwinCat users: Be aware that the system level designer might have chosen to disable direct error event reporting from the triamec module to the user. It is at the system level designers responsibility to propagate the plc-axis errors during commissioning in this case.

Some internal tests (flash and RAM-tests) are only done during 24V start-up and after resetting an STO fault. Make sure any one of the following procedures is done minimum once a year:

- Turn off 24V for at least 10s or
- Generate an STO error, e.g., STO-Inconsistent (a STO-Active warning is not sufficient) or
- Software activation of this error is also possible, ask Triamec Motion AG for details.

5.5.3 Functional Description

The drives main semiconductors may be activated only, if both STO channels are enabled, i.e., their voltage is high enough. These channels engage the power supply of the semiconductor drivers.

Cutting any of these two channels below U_{Safe}^{STO} will deactivate the drivers and the motors do not receive any energy after a maximum time of t_{Safe}^{STO} (process safety time). This feature has priority over software and may not be disabled by software. For external diagnostic purposes, the channels may be pulsed with 0V pulses of maximum duration t_{Ignore}^{STO} at a maximum rate of f_{Ignore}^{STO} .

Standard case: If STO is activated simultaneously on both channels as intended, the drive will enter a safe state:

- The warning state "**Not-ReadyToSwitchOn/STO-Active**" is entered when STO is activated from the switched off state "*ReadyToSwitchOn*". This state is left without reset, if the STO is inactivated.
- The error state "**FaultPending/STO-Active**" is entered when STO is activated from the switched on state "*Operational*". This state is left only with a reset command. The next state is either a warning state "*Not-Ready-ToSwitchOn*" if a warning condition is still active (i.e., STO-active, temperature, bridge-voltage) or the ready state, if the STO is inactivated.

Serious case: In addition to these standard "Safe-States", there are a couple of "Safe-Error-States". These require a user initiated reset for recovery. During recovery, there is a power-up test of the internal diagnostic circuit which takes about 40ms. The important causes from a user perspective are:

- If the logic levels of the two channels are not equal during more than $t_{Inconsistent}^{STO}$, the drive enters the safe error state **STO-Inconsistent**.
- Internal diagnostic startup test failure: The drive enters the safe error state **startup test of the safety circuit failed**.
- Internal periodic pulse test failure: The drive enters the safe error state **STO-PulseTestFailure**.
- If the internal diagnostic circuit temperature is out of range, the drive enters the safe error state **STO-Temperature-Limit**.

The following hardware considerations justify a special note:

A spontaneous defect of two power semiconductors may cause a maximum movement of 120° (electrically), but this is very unlikely.

Voltages outside of the specifications:

- The STO inputs are protected up to voltages of 40V by a thermal (recoverable) fuse.
- If the 24V Supply voltages exceed 29V, the drive will enter and remain in the safe state. For Rev. 1 an irreversible fuse will break and the drive requires factory maintenance. For Rev. 2 and higher, the internal power supply switches off and the drive requires a 24V power cycle.
- Too small 24V supply voltages also cause entering the safe state.

5.5.4 Safety characteristic data

The safety specifications (in addition to the electrical STO specs in chapter 5.2.1) are

- Safety level SIL 3
PLe CAT 3
- PFH 3E-9 h⁻¹
PFD 2E-4 (Proof-Test Interval = Mission Time)
- SFF 95%STO (Hardware Fault Tolerance HFT1)
96%Diagnostics (Hardware Fault Tolerance HFT0)
- Type A (according to 61508-2)
- DC 92%
- MTTFd 100a
- Mission time TM 20a

5.5.5 Prohibited Use

The STO function must not be used in the following cases:

Cleaning, maintenance, repair operations and long inoperative periods:

In such cases, the entire system should be disconnected from the supply by the personnel, and secured (main switch).



Symbol	Safety Information
	<p>Risk of injury from suspended loads! If the STO function is activated, the amplifier cannot hold the load, the motor no longer supplies torque. Drives with suspended loads must also be safely blocked using a mechanical means (e.g. with the motor holding brake). If engaged during operation, the motor runs down out of control. There is no possibility of braking the drive controlled. If a controlled braking before the use of STO is necessary, the drive must be braked and the STO inputs have to be separated from +24 VDC in a time-delayed manner.</p> <p>Keep to the following functional sequence when STO is used :</p> <ol style="list-style-type: none"> 1. Brake the drive in a controlled manner (command stop or emergency stop) 2. When speed = 0 rpm, disable the servo amplifier (enable = 0V) 3. If there is a suspended load, block the drive mechanically 4. Activate STO (STO1-Enable and STO2-Enable = 0V)
	<p>The function STO does not provide an electrical separation from the power output. If access to the motor power terminals is necessary, the servo amplifier must be disconnected from mains supply considering the discharging time of the intermediate circuit. There is a danger of electrical shock with personal injury.</p>

Table 12: Safety Information STO.

5.6 Mechanical specifications

	TSD80, TSD130
Weight	1370g
Dimensions: W x H x D	51 x 230 x 170mm ³





5.7 Ambient and mounting conditions

TSD80, TSD130	
Site altitude	up to 1000m above sea level without restriction, higher than 1000m above sea level with reduced power 1% per 100m, max. 2500m above sea level
Mounting Position	Vertical or horizontal, see 6.2
Ambient temperature in operation	According to IEC60721-3-3 class 3K3 +5°C (41°F) to +40°C (104°F), max. rate of change 20K / hour
Humidity in operation	5 to 85% without condensation
Cooling System	The unit has a fan which is speed controlled. This increases the life time of the fan and reduces acoustic noise. Care should be taken not to block the air inlet on the right side of the unit. The drive is equipped with temperature monitoring at various positions inside the drive, which switches the drive off in case of over-temperature. The drive switches off if the heat sink temperature is above 70°C (158°F).
Enclosure protection	IP 20 (according to IEC 60529 standard)
Pollution Level	Level 2 as per IEC 60664-1
Type of installation	Built-in unit, only for installation in a stationary control cabinet with min. degree of protection IP4x. According to EN ISO 13849-2 the control cabinet must have degree of protection IP54 or higher when using the safety function STO (Safe Torque Off).
Vibrations of System	The drive is intended for stationary use only and must not be installed in areas where they would be permanently exposed to vibrations. The mechanical conditions must respect the class 3M3 of the IEC 60721-3-2 standard.

Table 13: Ambient conditions.

6 Mechanical Installation

6.1 Safety Instructions

Symbol	Safety Information
	<ul style="list-style-type: none"> - There is a danger of electrical shock by high EMC level which could result in injury, if the servo amplifier (or the motor) isn't properly EMC-grounded. - During installation work strictly avoid that drill chips, screws or other foreign substances drop into any device. Strictly prevent the devices from moisture. - Protect the servo amplifier from impermissible stresses. In particular, do not let any components become bent or any insulation distances altered during transport and handling. Avoid contact with electronic components and contacts.
	<ul style="list-style-type: none"> - The device heats up during operation and the temperature on the heat sink may reach high temperatures. Please bear this in mind for adjacent components. - Cooling air must be able to flow through the devices without restriction. For installation in control cabinets with convection, always fit an internal air circulation fan. - The servo drive will switch-off itself in case of overheating. Ensure that there is an adequate cooling in the control cabinet.
	<ul style="list-style-type: none"> - Protect the servo amplifier from impermissible stresses. In particular, do not let any components become bent or any insulation distances altered during transport and handling. Avoid contact with electronic components and contacts.
	<p>Don't mount devices, which produce magnetic fields, directly beside the servo drive. Strong magnetic fields could directly affect internal components. Install devices which produce magnetic field with distance to the servo drive and/or shield the magnetic fields.</p>

Further information and instructions can be found in Table 13: Ambient conditions.

6.2 Guide to mechanical installation

The following notes help to carry out the mechanical installation

Site

- The servo drive should be mounted into a lockable control cabinet. Refer to chapter 5.7.
- The site must be free from conductive or corrosive materials.

Cooling

- The drives shall be spaced with a gap of 5mm laterally.
- The servo drive will shut down if the temperature on the PCB, below the power stage, reaches 70°C.

Mounting

- Assemble the servo drives and power supply close together, on the conductive, grounded mounting plate in the cabinet.
- Mount the drive preferably in vertical position as depicted in Figure 4 (horizontal position is allowed too). There are two mounting holes for this purpose for M4-Screws in a distance of 220mm at the back side of the drive.
- The Dimensions of drive and the mounting hole positions are shown in chapter 5.6.

	TSD80, TSD130
Gap between drives	5mm
Screws	2 x M4 or M5

Table 14: Distances of drives in cabinet.

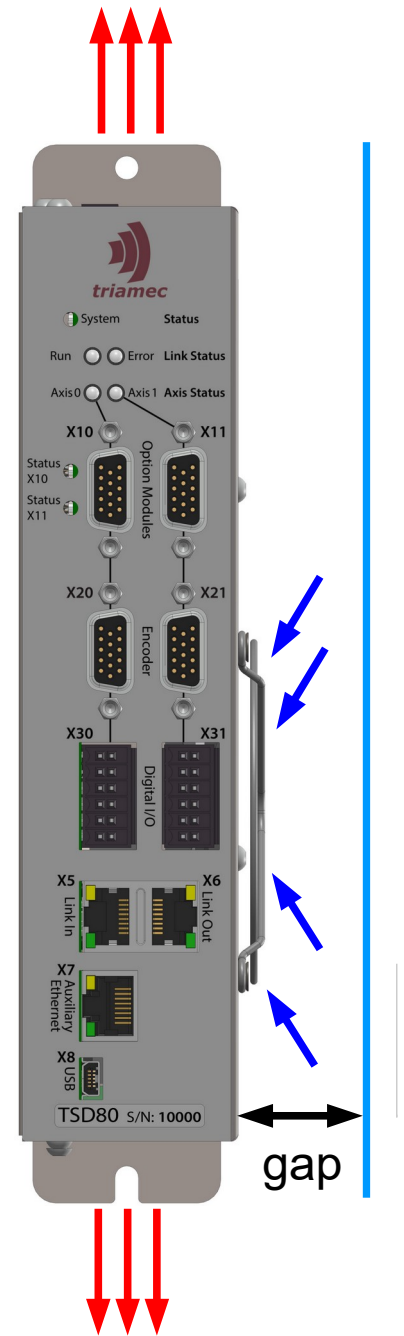











Figure 4: Mounting and cooling.

7 Electrical Installation

7.1 Safety Instructions

Symbol	Safety Information
	<p>There is a danger of electrical arcing with serious personal injury. Never connect or disconnect electrical connections while power of any source is on. Isolate the device from the power supply before working on it. Wait at least ten minutes after disconnecting the servo drive from the main supply power before touching potentially live sections of the equipment (e.g. contacts) or undoing any connections. Control and power connections can still be live, even if the motor is not rotating. Capacitors can still have dangerous voltages present up to ten minutes after switching off the power supply. Work on the device must only be carried out, after the DC link voltage has dropped below a residual voltage of 40V (to be measured on terminal X1).</p>
	<p>Installation is permitted for properly qualified personnel only. Only professional staff who are qualified in electrical engineering are allowed to install the servo drive. The qualified personnel must know and observe the following standards:</p> <ul style="list-style-type: none"> • IEC 60364 and IEC 60664 • national accident prevention regulations
	<p>During installation work strictly avoid that screws, cable oddments or other foreign substances drop into any device. Strictly prevent the devices from moisture.</p>
	<p>Wrong DC-Bus voltage, unsuitable motor or wrong wiring will damage the amplifier. Check the combination of servo amplifier and motor. Compare the rated voltage and current of the units. Implement the wiring according to the connection diagram in Chapter 7.4. Make sure that the maximum permissible rated voltage at the terminal X1 is not exceeded by more than 5%.</p>
	<p>Compliance with the EMC product standard Commissioning (i.e. starting intended operation) is only permitted when strictly complying with EMC product standard EN 61800/-3:2004. The installer/operator of a machine and/or equipment must provide evidence of the compliance with the protection targets stipulated in the EMC-standard.</p>
	<p>Correct wiring is the basis for reliable functioning of the servo system. Route power and control cables separately. We recommend a distance of at least 100mm. This improves the interference immunity.</p>
	<p>Use only shielded motor and signal lines with double copper braiding that is overlapping by 60 to 70 %.</p>
	<p>Feedback lines may not be extended, since thereby the shielding would be interrupted and the signal processing could be disturbed.</p>
	<ul style="list-style-type: none"> – Always route the motor cable without interruptions and the shortest way out of the control cabinet. – If possible enter signal lines only from one side into the control cabinet. – Lines of the same electric circuit must be twisted. – Avoid unnecessary cable lengths and loops.

7.2 Guide to electrical installation

The following notes help to carry out the electrical installation. The installation procedure is described as an example. A different procedure may be appropriate or necessary, depending on the application of the equipment.

Connectors and cables

- Select cables according to the specification of each connector in chapter 7.

Grounding

- For EMC-compliant grounding refer to chapter 7.4.2.
- Make sure there are two protective earth connections.
- Ground the mounting plate, motor housing and the GND of the control system.

Wiring and shielding

NOTE: Route power leads and control cables separately.

- Connect the protective earth (PE) to the dedicated screws!
- Wire the STO contacts as discussed in chapter 7.5.
- Connect the digital inputs and outputs.
- Connect the auxiliary Supply for the digital outputs.
- Connect the feedback device (encoder) and its shielding.
- Connect the motor cable and its shielding at both ends.
Make sure the length is within the EMC specification in chapter 5.2.3.
- Connect motor-holding brake if needed and its auxiliary supply, connect shielding at both ends.
- Connect the DC-Bus to the Power supply. Make sure the DC-Bus connection to the power supply is as short as possible.
- Connect the field bus (Tria-Link or EtherCAT).

Final check

- Final check of the wiring against the wiring diagrams that have been used.

7.3 Overview of Drive Connections

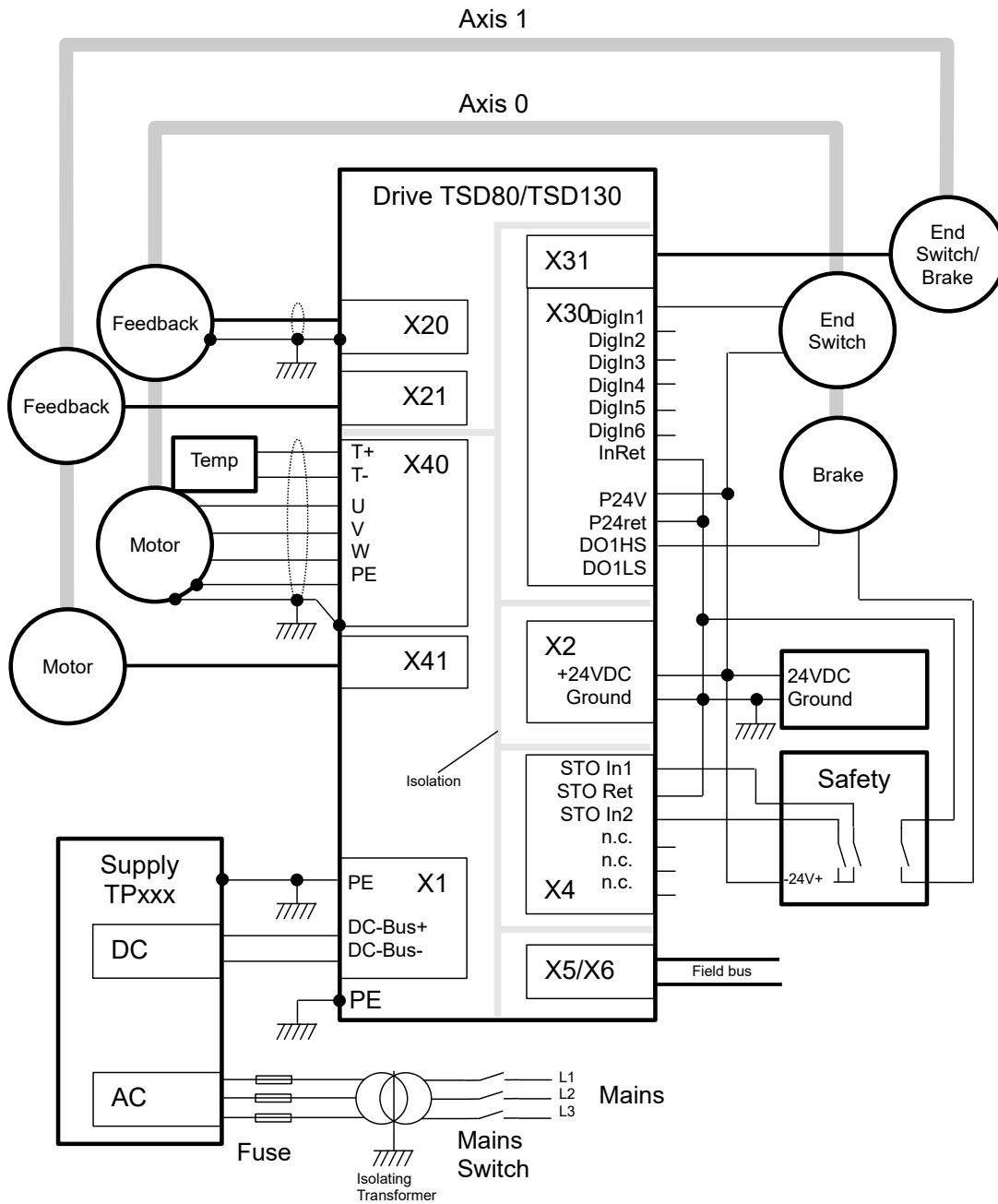

Figure 5: Connection diagram TSD80/TSD130.

The illustration on the right side shows the drive with the corresponding positions of plugs and terminals. All signals of the servo drive are accessible from the front plate. Power connectors, STO and 24V supply are at the top side of the drive. Motor connectors are located at the bottom of the drive.

The second earth contact PE and the PE wire of connector X1 must both be connected to protective earth with a wire cross-section equivalent to the DC-Bus wires or more.

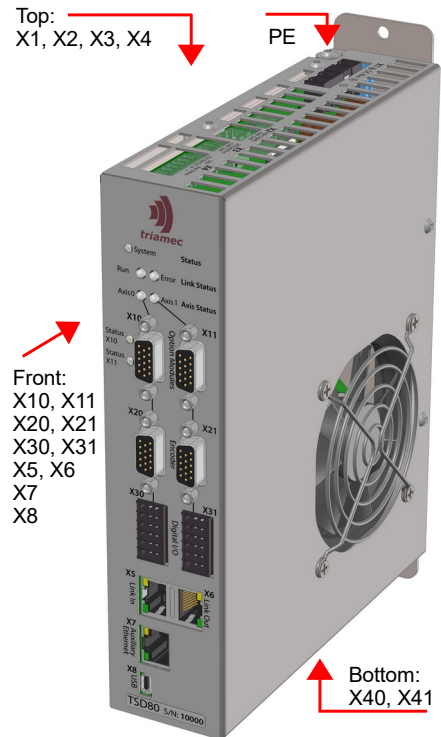

Figure 6: Overview of the connectors.

Connectors and Terminals

Connector	Direction	Terminals	Type	Details
X1	In	DC-Bus	Weidmüller, BLZ 7.62IT/03/180MF2 SN BK Order-No.: 1173500000, 3 pins, 7.62mm pitch	7.4.2
X2	In	Logic Supply (24V)	Weidmüller, BLF 5.08HC/02/180 SN BK BX Order-No.: 1013430000, 2 pins, 5.08mm pitch	7.4.1
X3	Out	STO Power	Weidmüller, BL 3.50/02/180 SN BK BX Order-No.: 1615670000, 2 pins, 3.5mm pitch	7.5
X4	In	Safe torque Off	Weidmüller, BL 3.50/06/180 SN BK BX Order-No.: 1610180000, 6 pins, 3.5mm pitch	5.5, 7.5
X5/X6	In/Out	Tria-Link or EtherCAT	RJ-45 connector	7.6
X7	In/Out	The auxiliary Ethernet connector is currently unused. It is intended for future TCP/IP compatible operation of the TSD80.		
X8	In/Out	The USB connector (mini-B) can be connected to a Microsoft® Windows® based notebook/PC. Together with Triamec's TAM-Explorer, the drive can be monitored („observed“) at any time.		
X10/X11	In/Out	Option modules	15 pin Sub-D (female) high-density connector	7.7
X20/X21	In	Encoder	15 pin Sub-D (female) high-density connector	7.8
X30/X31	In/Out	Digital I/O	Weidmüller, B2CF 3.50/12/180LH SN BK BX Order no.: 1375750000 (for coding, see option ²)	7.9
X40/X41	Out	Motor(s)	Weidmüller, BLF 5.08HC/06/180 SN BK BX Order-No.: 1013470000, 6 pins, 5.08mm pitch	7.10.1

Table 15: drive connectors.

2 Coding elements: Manufacturer: Weidmüller Type: B2L/S2L 3.50 KO BK Order No. 1849740000.

7.4 Electrical supplies

The power supply for the drive is separated into the supplies for logic and power sections.

NOTICE

The DC-Bus voltage can be switched on and off independently of the Logic Power. Standard operating procedure, however, is to power the logic before powering DC-Bus.

7.4.1 24V Logic supply (X2)

The servo drive requires a 24VDC supply (PELV type sufficient) for its internal logic and for the supply of the connected encoders.

The drive internal supplies are galvanically isolated from the 24VDC logic supply input, especially the encoder supply and the motor temperature input. The STO supply used to bypass STO is not galvanically isolated from this input.

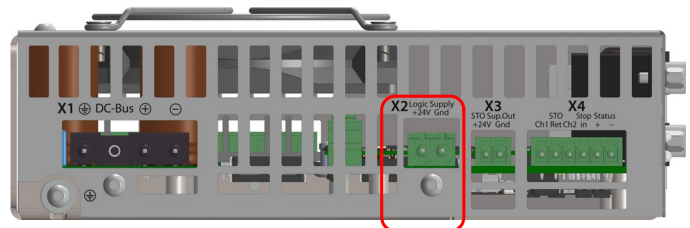

Figure 7: 24V Logic supply connector (X2).



Pin Layout X2	Pin	Name	Description
	1	+24VDC	Supply logic positive voltage
	2	Ground	Supply ground

Table 16: Pin out of the logic power supply connector.

	Information
	As per EN 61800-5-1, the used power supply must have a safe and reliable galvanic isolation towards the mains network.
NOTICE	It's recommended, to connect the 0VDC (-) to earth potential near the power supply.

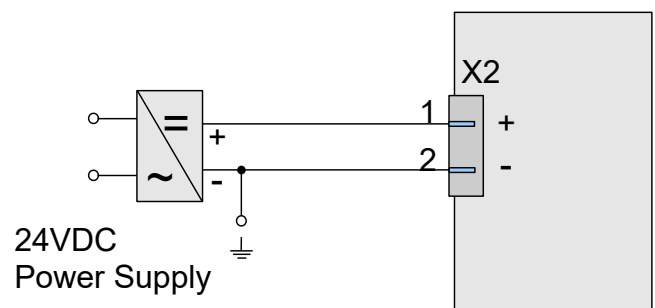

Figure 8: 24VDC logic power supply connection.

7.4.2 DC-Bus (X1)

The drive must be supplied with a DC voltage source as specified in chapter 5.2.1. Use the DC-bus connector X1 at the top side of the drive. There must be two protective earth connections.

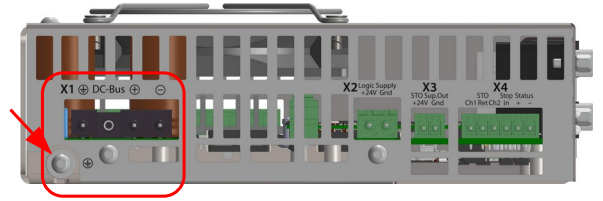
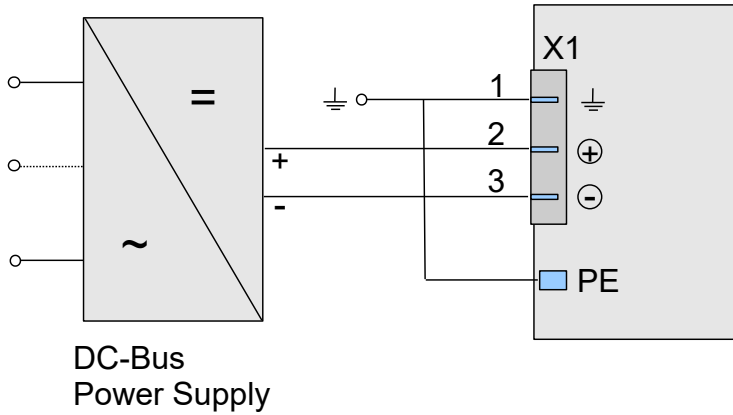

Figure 9: DC-Bus connector (X1).

Figure 10: DC-Bus connection.

Pin Layout X1	Pin	Name	Description	Cross-Section of Wire	Maximum Current
	1	PE	Protective earth	Same or larger than DC-Bus	
	2	+DC-Bus	DC- Bus positive voltage	1.5mm ² min, 2.5mm ² typ	20 A
	3	-DC-Bus	DC-Bus ground	1.5mm ² min, 2.5mm ² typ	20 A

Table 17: Pin out DC-Bus connector.

	Information
NOTICE	The Triamec Motion AG power supplies TP80 and TP130 complement these drives that do not include an integral power supply. Its recommended to use the Triamec power supplies, see also chapter 5.2.3 on EMC.
NOTICE	Power supply always must be galvanically isolated from the supply mains to comply with isolation requirements according to EN 61800-5-1.
	Hot-plugging of the DC-bus link connector is strictly forbidden. The servo drives have large internal capacitors. It is therefore also forbidden to have a simple power-switch or relay in the DC-bus link, because this will also cause large inrush currents. A power-switch or relay in the DC-bus link is allowed only, if it has a soft-start functionality as supplied by the Triamec power supplies TP80 and TP130.
	Please note if not using a Triamec power supply: The servo drives have no built in brake-resistor. When decelerating a mechanical load, currents can get negative, refer to chapter 5.4.

7.5 STO (X3+X4)

The STO connector X4 is found at the top side of the drive. The cable must be shorter than 20m. Use shielded cables if longer than 0.5m.

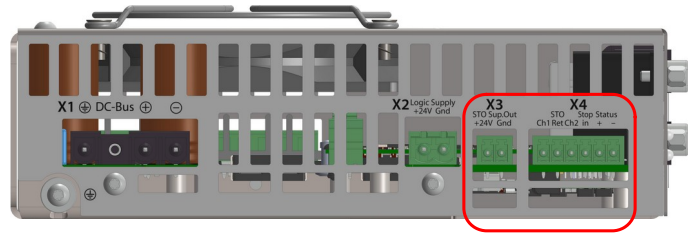

Figure 11: STO connectors (X3+X4).



Pin Layout X3	Pin	Name	Description
	1	internal STO 24 V	24 V for X4, if STO is not used (connect to Pin 1 and 3 of X4)
	2	internal STO GND	GND for X4 if STO is not used (connect to Pin 2 of X4)
Pin Layout X4	Pin	Name	Description
	1	STO Input 1	STO channel 1 input
	2	STO Return	GND
	3	STO Input 2	STO channel 2 input
	4	internal	Do not connect
	5	internal	Do not connect
	6	Internal	Do not connect

Table 18: Pin out of the Safe-Torque-Off (STO) connectors.

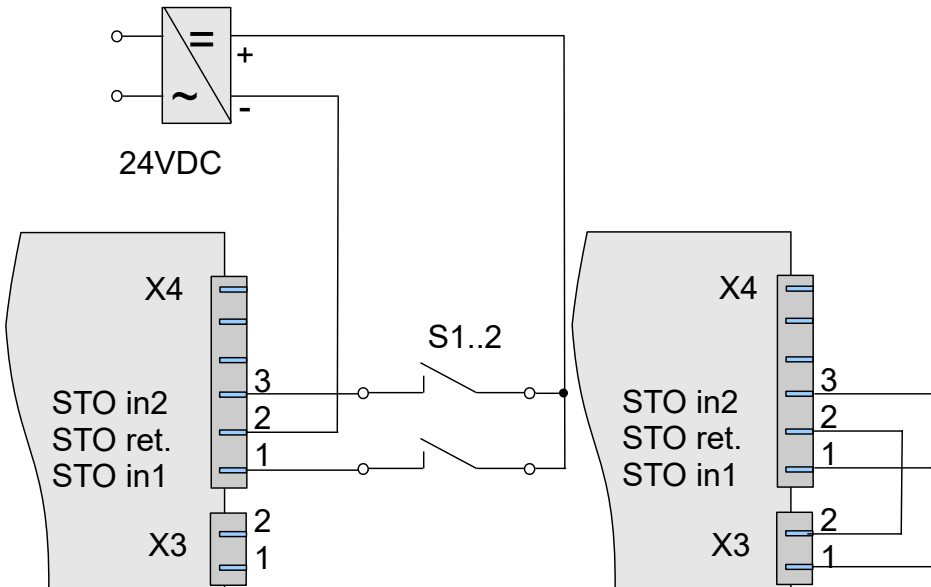

Figure 12: Wiring of the STO used (left) and not used (right).

7.6 Field-bus connection (X5, X6)

The servo drive communicates with the host (and other devices) using one of two Ethernet based field-buses.

Use quality Cat. 5E or 6, double shielded, standard Ethernet cables.

Tria-Link

This is a flexible bus developed by Triamec. The drive must be connected with the other Triamec devices and the Triamec PCI-Adapter card forming a ring topology. Both jacks (X5, X6) are equivalent, they can be used in any order and are completely interchangeable.

Each Tria-Link RJ-45 connector has two LEDs:

- The green LED (Link LED) is normally blinking. This indicates that the Tria-Link is connected to the next device. If one of the green LEDs is not blinking, it indicates an open link to the next device. Check device 24V and the cable/Ethernet connector in this case.
- The yellow LED (Lock LED) indicates a successful time synchronization of all devices in the Tria-Link, and thus that the link is ready. If the yellow LED is not illuminated at least ~5sec after drive start up, the Tria-Link is either:
 - ♦ open, i.e. the ring is not closed or an Ethernet connector is not engaged
 - ♦ one or more devices are not powered
 - ♦ a device has a hardware fault.

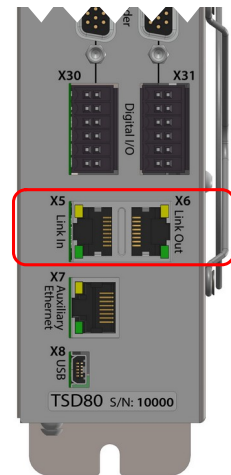

Figure 13: Tria-Link jacks (X5, X6).

EtherCAT

This is a fieldbus disclosed in the IEC standard IEC61158 with real-time capability. It was originally developed by Beckhoff Automation and is now managed by the EtherCAT Technology Group (ETG).

The drive must be connected to the EtherCAT PCI-Adapter card and the other Triamec devices in a chain topology starting with the Adapter card. The jacks (X5(Line In), X6(Line Out)) are not equivalent, the control flow has to be regarded.

- In contrast to the Tria-Link, the cyclic data is defined at boot time and cannot be changed later. This makes debugging through the fieldbus less flexible than with the Tria-Link. However, customers may still use the fast USB debugging feature with the Triamec TAM System Explorer.
- Exchange of cyclic data between slaves is less flexible than with Tria-Link and is not supported yet with the current firmware.

Each EtherCAT RJ-45 connector has two LEDs:

- The green LED (Line In) is on, to indicate that the drive is connected to the Controller. If the green LED is Off, it indicates an open connection. Check device 24V and the cable/Ethernet connector in this case.
- The yellow LED (Line Out) is normally Off, except the LED of the last Device in the chain is flashing.

7.7 Option Modules (X10, X11)

Two option module connectors access extended functions, if the corresponding option module is installed. Installation has to be done during production. Currently available functions are

- TOE1 An additional encoder input with the same specification as the built-in encoder (500kHz)
- TOE2 An additional fast encoder input with a cut-off frequency of 5MHz.
- TOF2 A pulse train output module
- TOU1 An analog input sampling module

Consult the option module quick start guide [6] for information on the option modules and chapter 3.1 for the order information.

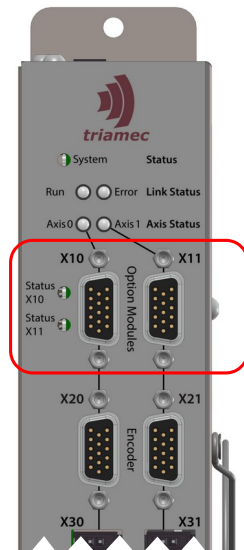



Figure 14: Option module jacks (X10,X11).

7.8 Feedback Systems (X20, X21)

Two encoder connectors are available by default (two more are available with option modules). They are located at the front side of the drive. X20 feeds axis 0. X21 feeds axis 1. Each connector supports various encoder types/protocols and some optional TTL inputs.

Information	
	<ul style="list-style-type: none"> - Make sure the encoder plug is well connected by means of the D-Sub plug screws. - Do not split encoder cables, for example to route the signals via terminals into the control cabinet. - Connect the case with the shielding of the encoder cable and make sure, that the screen is connected with low impedance (i.e. thick wire, large connection area, 360 degree around the cable) at the drive side.

The table below illustrates the use cases of the encoder connection. For pulse train options see chapter 7.7.

Use case	Function	Description
1	Analog Sin/Cos Encoder with index input	High resolution analog Sin/Cos encoder
2	Analog Sin/Cos Encoder input with EnDat interface	High resolution analog Encoder combined with absolute encoder position via EnDat 2.1/2.2.
3	Encoder with EnDat interface	Serial data encoder EnDat 2.2 without analog sin/cos signals (partially supported)
4	Incremental Encoder with index input	Incremental encoder, TTL and RS422 configurable.

Table 19: Encoder connection use cases on Connectors X20 and X21.

7.8.1 Analog Sin/Cos Encoder with Index

Analog (Sin/Cos) encoder with index channel.



Figure 15: Encoder jack (X20, X21).

Pin Layout X20/X21	Pin	Name	Encoder	
15-pin female D-Sub socket  female D-Sub socket	1	+5VDC	Encoder Supply	
	2	ChA+	Channel A positive, Cosine 1Vpp	
	3	ChB+	Channel B positive, Sine 1Vpp	
	4	ChZ+	Index channel positive, RS-422 input	
	5	n.c.	(do not connect)	
	6	Gnd	Supply Ground	
	7	ChA-	Channel A negative, Cosine 1Vpp	
	8	ChB-	Channel B negative, Sine 1Vpp	
	9	ChZ-	Index channel negative, RS-422 input	
	10	n.c.	(do not connect)	
	11	EnIn0	TTL Level Input No. 0 (max 5VDC Input)	see 7.8.6 for connection
	12	EnIn1	TTL Level Input No. 1 (max 5VDC Input)	see 7.8.6 for connection
	13	EnIn2	TTL Level Input No. 2 (max 5VDC Input)	see 7.8.6 for connection
	14	EnIn3	TTL Level Input No. 3 (max 5VDC Input)	see 7.8.6 for connection
	15	Gnd	Signal Ground	

Table 20: Pin out of the encoder connector used for analog encoder with index channel.

7.8.2 Analog Encoder with EnDat

Single-turn or Multi-turn analog (Sin/Cos) encoder with EnDat 2.1/2.2 interface. This encoder type is operated as analog Sin/Cos encoder. The absolute position (and some additional information) will be read within the digital serial interface using the EnDat2.1/2.2 protocol.

NOTICE RS422 index channel is not available in this configuration. TTL index is available through EncIoX.

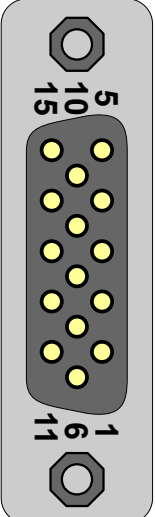
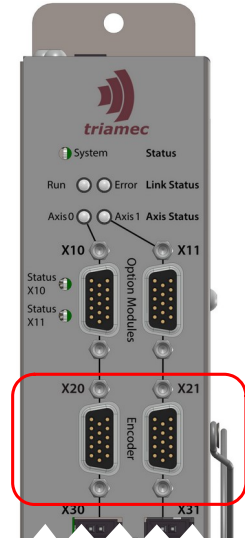

Figure 16: Encoder jacks (X20,X21).

Pin Layout X20/X21	Pin	Name	Encoder	
15-pin female D-Sub socket  female D-Sub socket	1	+5VDC	Encoder Supply	
	2	ChA+	Channel A positive, Cosine 1Vpp	
	3	ChB+	Channel B positive, Sine 1Vpp	
	4	DATA+	Data channel positive, RS-422	
	5	CLOCK+	Clock channel positive, RS-422	
	6	Gnd	Supply Ground	
	7	ChA-	Channel A negative, Cosine 1Vpp	
	8	ChB-	Channel B negative, Sine 1Vpp	
	9	DATA-	Data channel negative, RS-422	
	10	CLOCK-	Clock channel negative, RS-422	
	11	Encln0	TTL Level Input No. 0 (max 5VDC Input)	see 7.8.6 for connection
	12	Encln1	TTL Level Input No. 1 (max 5VDC Input)	see 7.8.6 for connection
	13	Encln2	TTL Level Input No. 2 (max 5VDC Input)	see 7.8.6 for connection
	14	Encln3	TTL Level Input No. 3 (max 5VDC Input)	see 7.8.6 for connection
	15	Gnd	Signal Ground	

Table 21: Pin out of the encoder connector used for analog encoder with EnDat 2.1.

7.8.3 Encoder with EnDat 2.2

Single-turn or Multi-turn Encoder with EnDat 2.1/2.2 interface without Analog sin/cos signals (Endat 2.2). Digital position information is transmitted at every position controller cycle digitally coded to the position controller.

NOTICE This encoder mode is usually not recommended and is **not supported yet** with the Beckhoff-TwinCAT interface. Ask Triamec Motion if you require this mode.

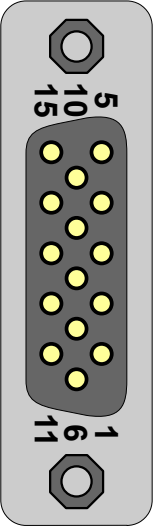
NOTICE RS422 index channel is not available in this configuration.

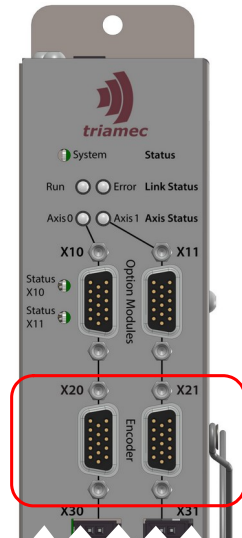

Figure 17: Encoder jacks (X20, X21).

Pin Layout X20/X21	Pin	Name	Encoder	
 <p>15-pin female D-Sub socket</p> <p>female D-Sub socket</p>	1	+5VDC	Encoder Supply	
	2	n.c.	(do not connect)	
	3	n.c.	(do not connect)	
	4	DATA+	Data channel positive, RS-422	
	5	CLOCK+	Clock channel positive, RS-422	
	6	Gnd	Supply Ground	
	7	n.c.	(do not connect)	
	8	n.c.	(do not connect)	
	9	DATA-	Data channel negative, RS-422	
	10	CLOCK-	Clock channel negative, RS-422	
	11	Encln0	TTL Level Input No. 0 (max 5VDC Input)	see 7.8.6 for connection
	12	Encln1	TTL Level Input No. 1 (max 5VDC Input)	see 7.8.6 for connection
	13	Encln2	TTL Level Input No. 2 (max 5VDC Input)	see 7.8.6 for connection
	14	Encln3	TTL Level Input No. 3 (max 5VDC Input)	see 7.8.6 for connection
	15	Gnd	Signal Ground	

Table 22: Pin out of the encoder connector used for encoder with EnDat 2.2.

7.8.4 Incremental RS422 Encoder with Index

Connecting an incremental encoder with index channel.

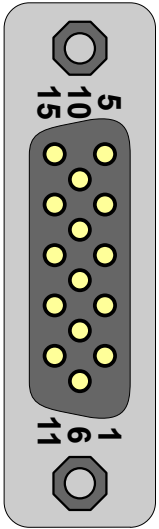
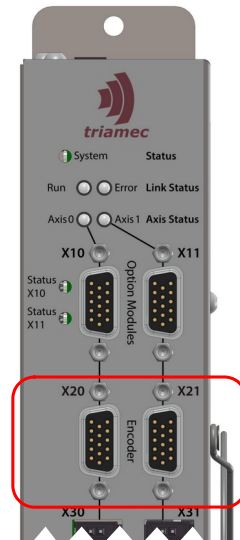

Figure 18: Encoder jacks (X20, X21).

Pin Layout X20/X21	Pin	Name	Encoder	
15-pin female D-Sub socket  female D-Sub socket	1	+5VDC	Encoder Supply	
	2	ChA+	Channel A positive, RS-422 input	
	3	ChB+	Channel B positive, RS-422 input	
	4	ChZ+	Index channel positive, RS-422 input	
	5	n.c.	- (do not connect)	
	6	Gnd	Encoder Ground	
	7	ChA-	Channel A negative, RS-422 input	
	8	ChB-	Channel B negative, RS-422 input	
	9	ChZ-	Index channel negative, RS-422 input	
	10	n.c.	- (do not connect)	
	11	Encln0	TTL Level Input No. 0 (max 5VDC Input)	see 7.8.6 for connetion
	12	Encln1	TTL Level Input No. 1 (max 5VDC Input)	see 7.8.6 for connetion
	13	Encln2	TTL Level Input No. 2 (max 5VDC Input)	see 7.8.6 for connetion
	14	Encln3	TTL Level Input No. 3 (max 5VDC Input)	see 7.8.6 for connetion
	15	Gnd	Signal Ground	

Table 23: Pin out used for the incremental encoder.

7.8.5 Incremental TTL Encoder with Index

Connecting an incremental TTL encoder with index channel via Encln0 and Encln1.

NOTICE

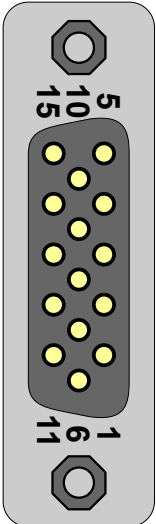
The source for position latch during homing can be chosen between ChZ (RS-422) or Encln2/3 in the software.

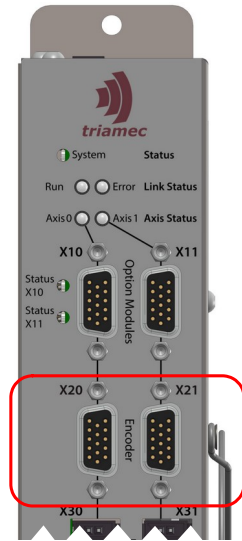

Figure 19: Encoder jacks (X20,X21).

Pin Layout X20/X21	Pin	Name	Encoder	
15-pin female D-Sub socket  female D-Sub socket	1	+5VDC	Encoder Supply	
	2	n.c.	- (do not connect)	
	3	n.c.	- (do not connect)	
	4	ChZ+	Index channel positive, RS-422 input	
	5	n.c.	- (do not connect)	
	6	Gnd	Encoder Ground	
	7	n.c.	- (do not connect)	
	8	n.c.	- (do not connect)	
	9	ChZ-	Index channel negative, RS-422 input	
	10	n.c.	- (do not connect)	
	11	Encln0	Channel A	
	12	Encln1	Channel B	
	13	Encln2	TTL Level Input No. 2 (max 5VDC Input)	see 7.8.6 for connetion
	14	Encln3	TTL Level Input No. 3 (max 5VDC Input)	see 7.8.6 for connetion
	15	Gnd	Signal Ground	

Table 24: Pin out used for the incremental TTL encoder.

7.8.6 TTL Inputs Connection

If digital TTL inputs Encln0 ... Encln3 are used, they must be wired as follows using pull-up resistors.

We recommend pull-up resistors with 2.2kOhm. Shielding is mandatory for better EMC immunity. The shield has to be connected to the D-Sub housing (earth).

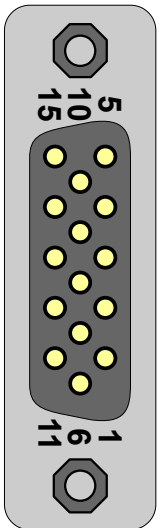
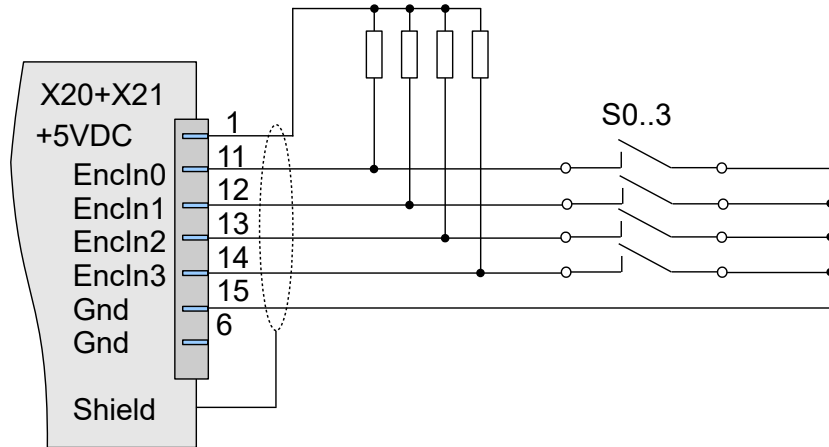

Figure 20: TTL input connection

7.9 Digital inputs and outputs (X30+X31)

The digital inputs and outputs are available at the front side of the drive. All inputs and outputs are galvanic isolated from the logic supply. The connectors X30 and X31 are not galvanically isolated to each other. X30 is assigned to axis 0, X31 to axis 1.

NOTICE The use of the inputs does not require a 24VDC supply (pin 1), however, the outputs need it.

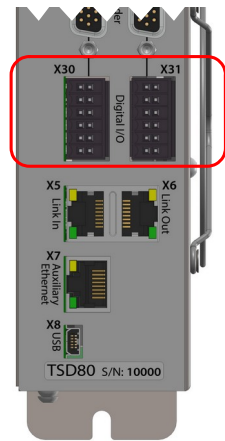

Figure 21: Digital I/O connector (X30+X31).

7.9.1 Digital inputs

The pin numbering of the connector is shown in the figure below, see chapter 5.2.1 for detailed specifications of the input channels.

Pin Layout X30/X31	Pin	Name	Description
	6	P24Vret	0V, ground for digital inputs. Internally connected to pin 2.
	7	DigIn1	Digital input 1
	8	DigIn2	Digital input 2
	9	DigIn3	Digital input 3
	10	DigIn4	Digital input 4
	11	DigIn5	Digital input 5
	12	DigIn6	Digital input 6

Logic low <5V
Logic high >18V, max 29V

Table 25: Pin out Digital-I/O Connector (Inputs).

The digital inputs can be connected as depicted in the illustrations below.

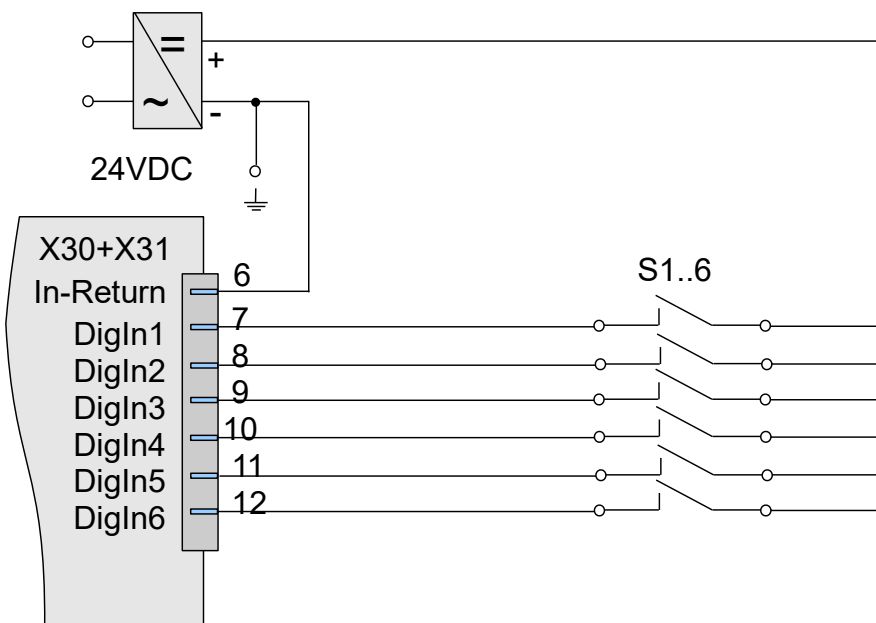

Figure 22: Digital input connection.

7.9.2 Digital Outputs

The table below describes the pin out of the output pins, see chapter 5.2.1 for detailed specification of the output channels. The digital outputs are high-side switches and require an external supply between pin1 and pin2 for operation. The next chapter shows an example wiring for a motor-holding brake.

Pin Layout X30/X31	Pin	Name	Description
	1	P24V	6...28VDC supply input for digital outputs 1 & 2. Current max. 2A continuous.
	2	P24ret	0V, ground for digital outputs. Internally connected to pin 6.
	3	DO1HS	Digital Output 1 High-Side Switch. Connect your load between this pin and <ul style="list-style-type: none"> pin 2 (P24V-return) OR pin 4, DigOut1LS, for safety operation 30VDC max, 1A continuous, 2A peak (1s)
	4	DO1LS	Digital Output 1 Low Side Switch to be operated together with pin 3, DigOut1HS, for safe brake operations (not certified yet). 30VDC max, 1A continuous, 2A peak (1s)
	5	DO2HS	Digital Output 2 High Side Switch. Connect your load between this pin and pin 2 or 6 (P24V-return) 30VDC max, 1A continuous, 2A peak (1s)

Table 26: Pin out Digital-I/O Connector (Outputs).

7.9.3 Motor-Holding brake

The motor-brake is an example of the digital output in the last chapter. The pin 4 (DO1LS) is connected to GND in standard operation and not connected during STO. This allows safe brake operation (not certified yet).

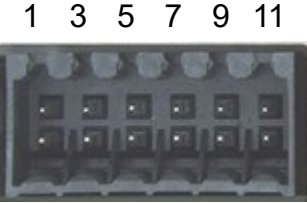
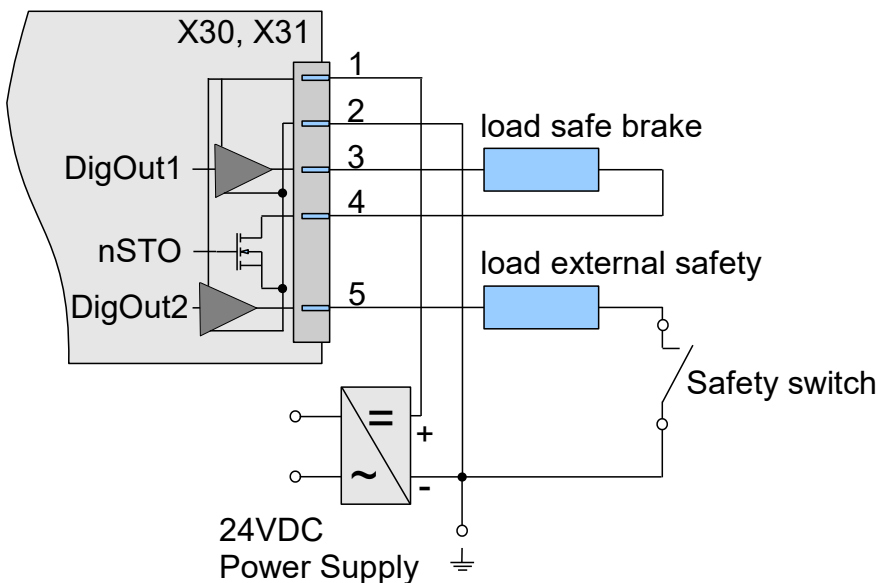

Figure 23: Typical motor brake connection with external safety switch (bottom) or with (uncertified) safe brake function (top).

7.10 Motor connection (X40+X41)

This connector feeds the motor windings and an external temperature sensor.

7.10.1 Motor Power Connection

The drive supports different motor configurations. All motor configurations use connectors at the bottom side of the drive. X40 is for axis 0 and X41 is for axis 1. The motor cable must be shielded. The illustrations below show all possible motor configurations for each axis.

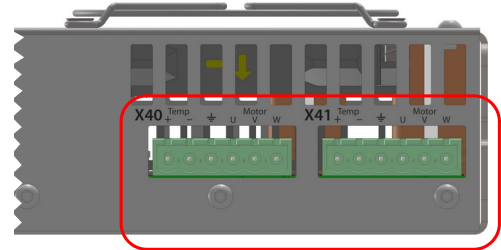

Figure 24: Motor connectors.

NOTICE

Make sure that the earth connection is made.

NOTICE

It is recommended to attach the motor shield directly to the electrical earth of the cabinet.

3-Phase AC Motor connection

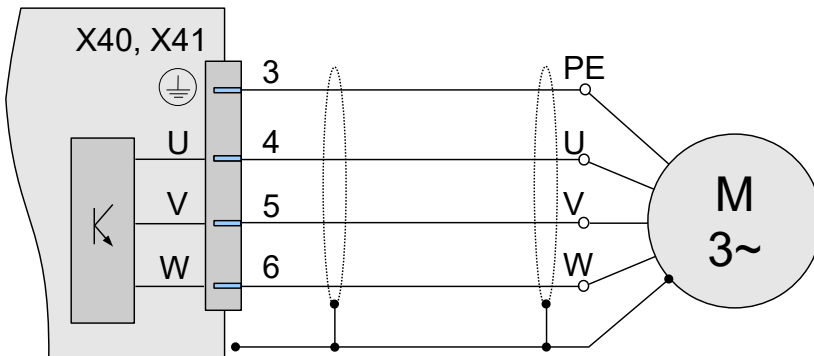

Figure 25: 3-phase motor connection.

Pin Layout X40/X41	Pin	Name	Description	Cross-Section of Wire	Maximum Current
 1	3	PE	Protective earth	Same or larger than UVW	
2	4	U	Motor phase U voltage	1.5mm ² min, 2.5mm ² typ	15 Arms
3	5	V	Motor phase V voltage	1.5mm ² min, 2.5mm ² typ	15 Arms
4	6	W	Motor phase W voltage	1.5mm ² min, 2.5mm ² typ	15 Arms
5					
6					

Table 27: Pin out of the motor connector when connecting a 3 phase AC motor.

2-Phase AC Motor connection

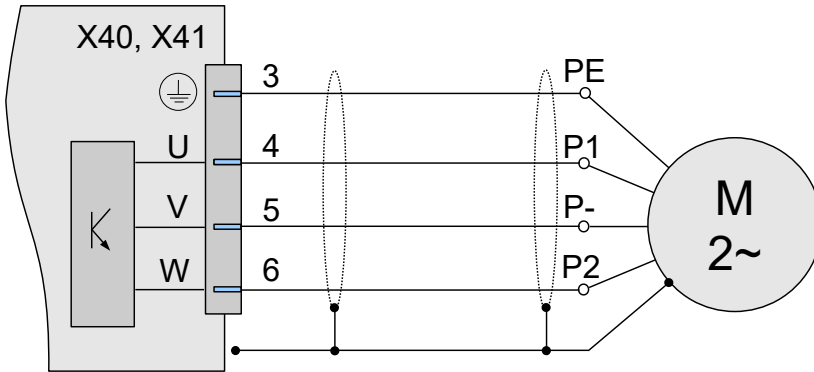

Figure 26: 2-phase motor connection.

Pin Layout X40/X41	Pin	Name	Description	Cross-Section of Wire	Maximum Current
 1	3	PE	Protective earth	Same or larger than UVW	
2	4	U	Motor phase P1 voltage	1.5mm ² min, 2.5mm ² typ	15 Arms
3	5	V	Motor phase P voltage	1.5mm ² min, 2.5mm ² typ	15 Arms
4	6	W	Motor phase P2 voltage	1.5mm ² min, 2.5mm ² typ	15 Arms
5					
6					

Table 28: Pin out of the motor connector when connecting a 2 phase AC motor.

DC Motor connection

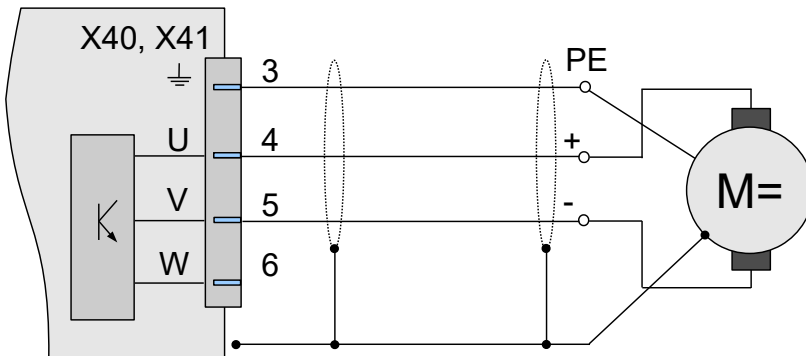

Figure 27: DC-motor connection.

Pin Layout X40/X41	Pin	Name	Description	Cross-Section of Wire	Maximum Current
 1	3	PE	Protective earth	Same or larger than UVW	
2	4	U	Motor phase DC+ voltage	1.5mm ² min, 2.5mm ² typ	15 Arms
3	5	V	Motor phase DC- voltage	1.5mm ² min, 2.5mm ² typ	15 Arms
4	6	W	nc	-	-
5					
6					

Table 29: Pin out motor connector, connecting DC motor.

7.10.2 Motor temperature

A resistive motor temperature sensor which measures the temperature of the motor windings may be connected to X40 and X41, see chapter 5.2.1 for supported types and ranges. Use X40 for axis 0 and X41 for axis 1.

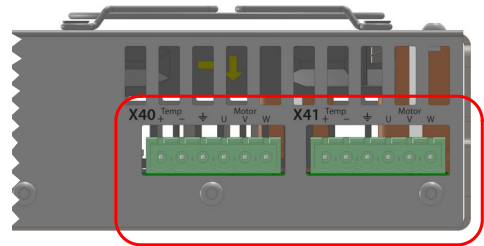

Figure 28: Motor temperature connector.

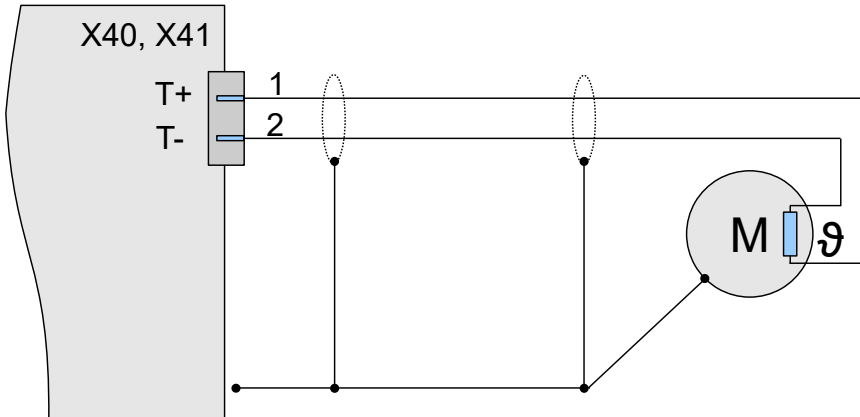

Figure 29: Motor temperature connection.







Pin Layout X40/X41	Pin	Name	Description
	1	T+	Positive input
	2	T-	Negative input
	3		
	4		
	5		
	6		

Table 30: Pin out of the motor temperature connector (X40, X41).

Information	
NOTICE	The temperature measurement input is on the same ground as the DC-Bus negative voltage and is galvanically isolated from the internal logic of the drive.

8 Commissioning and Diagnostics

The following utilities are available for commissioning

- The TAM System Explorer software which is used for all commissioning and analysis work flows
- The setup guide [2].
- The Beckhoff TwinCat Interfaces for Tria-Link drives ([3]) and for EtherCAT drives ([4]).

Immediate state information is available through five bi-colored LEDs on the front side. These indicate the actual state of the drive.

- The System Status LED indicates the overall drive state and faults.
- The two Link Status LEDs indicate if the field bus is operating (**Run** is steady green) or in error state (**Error** is red).
- The two Axis Status LEDs indicate if an axis is enabled (steady green) or in a fault state (blinking red).

The following illustrations show the possible blink sequences and their meaning.

Blink sequence during start-up:

System Status LED	6.5s	0.4s	0.4s
Axis Status Axis 0 LED	6.5s	0.4s	0.4s
Axis Status Axis 1 LED	6.5s	0.4s	0.4s

Normal idle operation is signaled by green blinking of the system LED with a period of 1.31 s. (All drives in a field bus should blink synchronously)

System Status LED	~0.6s	~0.6s	~0.6s	~0.6s	~0.6s	~0.6s
Axis Status Axis0 LED						
Axis Status Axis1 LED						

System warning (bridge voltage...) is indicated by a one red flash per period of 1.31 s.

System Status LED						
Axis Status Axis 0 LED						
Axis Status Axis 1 LED						

System error (STO fault, temperature limit,): Two flashes

System Status LED						
Axis Status Axis 0 LED						
Axis Status Axis 1 LED						

Axis 0 is in error state (e.g., positionErrorLimit, over-current, ...) and axis 1 is operational

System Status LED						
Axis Status Axis 0 LED						
Axis Status Axis 1 LED						

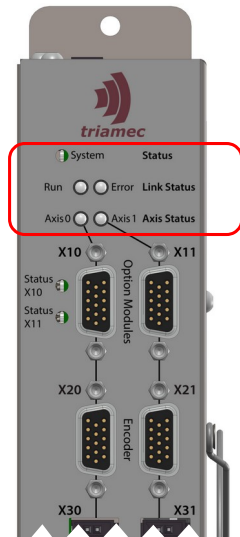

Figure 30: Status LEDs.



9 Appendix

9.1 Warranty Information

The products covered in this manual are warranted to be free of defects in material and workmanship and conform to the specifications stated either within this document or in the product catalog description. All Triamec Motion AG products are warranted for a period of 12 months from the time of installation, or 18 months from time of shipment, whichever comes first. No other warranties, expressed or implied – and including a warranty of merchantability and fitness for a particular purpose – extend beyond this warranty.

9.2 Service

We are committed to quality customer service. In order to serve in the most effective way, please contact the Customer Support at Triamec Motion AG for assistance.

Triamec Motion AG

Industriestr. 49
CH-6300 Zug
Switzerland

Phone: +41-41-747 4040

E-mail: info@triamec.com

Web: www.triamec.com

References

The documents referenced in this manual

- [1] "TP50-TP350 Power Supplies Hardware Manual",
HWTP50-TP350_E_HardwareManual_EP001.pdf, Triamec Motion AG, 2016.
- [2] "Drive Setup Guide",
SW_TSD-TSP360-TSP710-Setup-Guide_EP001.pdf, Triamec Motion AG, 2019.
- [3] "Triamec TwinCat, Quick Startup Guide",
SWTC_TwinCAT-UserGuide_EP024.pdf, Triamec Motion AG, 2016.
- [4] "Triamec TwinCat EtherCAT, Quick Startup Guide",
SWTC_TwinCAT-UserGuideEcat_EP003, Triamec Motion AG, 2018.
- [5] VDE_0160-101__DIN_EN_61800-1__1999-08.pdf.
- [6] "HWTO_A_QuickStartGuide", HWTO_QuickstartGuide.pdf.



Revision History

Version	Date	Editor	Comment
001	2017.09.12	ab+up+mvx +lh	First release
002	2018.08.09	ab	Update after first release of TSD80 Revision 4 manual
003	2019-09-23	chm	General review and renamings
004	2024-04-18	ab	Add 'TTL Inputs Connection' description