

# Encoder Splitter Manual

## *Splitter for Encoder Cables from Encoder to Drive/Observer*

Split the encoder signals between multiple readout devices.

### Table of Contents

1. Introduction.....	2	2.3. Clock and Data channels.....	4
1.1. Connections.....	2	2.4. Digital TTL channels.....	4
1.2. Power supply.....	2	2.5. Ground.....	4
2. Connections inside the encoder splitter.....	3	3. Compatibility.....	5
2.1. Encoder supply.....	3	Revision History.....	6
2.2. Analog channels.....	3		

## 1. Introduction

With the help of a TAES encoder splitter, an encoder cable, and therefore an encoder signal, can be split into two, allowing the encoder signal to feed two different systems.

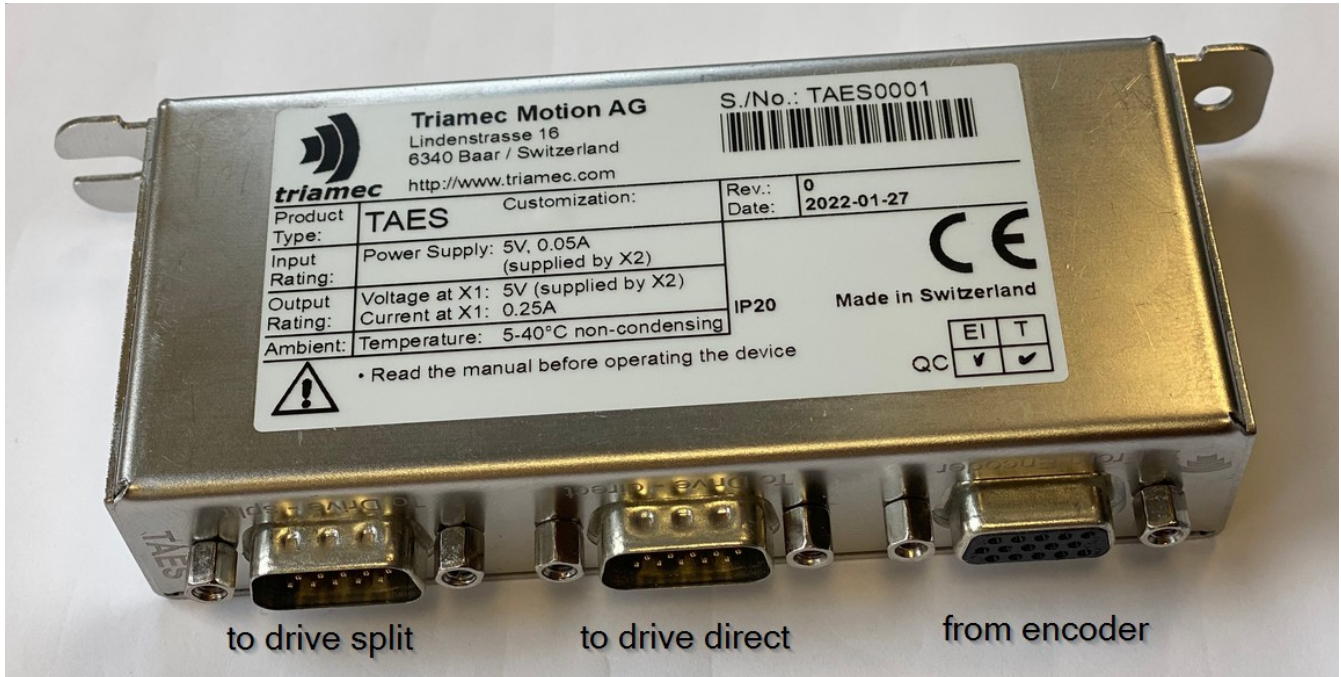

Figure 1: Image of the TAES encoder splitter with information tag.

### 1.1. Connections

The TAES encoder splitter has three connectors. One female 15-pin high-density D-Sub connector (X1, from the encoder) and two male connectors (X2, to the drive, and X3, to drive split), as seen in Figure 1. The pin out of the connectors is shown in Table 1.

### 1.2. Power supply

The encoder splitter does not require an external power supply. It is supplied by the 5VDC encoder supply coming from the drive (attached at X2).

Pin Layout Encoder	Pin	Name	Encoder
X1: 15-pin female D-Sub socket X2, X3: 15-pin male D-Sub socket (mirrored)	1	+5VDC	Encoder Supply
	2	ChA+	Channel A positive, Cosine 1Vpp
	3	ChB+	Channel B positive, Sine 1Vpp
	4	ChZ+	Index channel positive, RS-422 input
	5	Clk+	Clock channel positive, RS-422 input
	6	Gnd	Supply Ground
	7	ChA-	Channel A negative, Cosine 1Vpp
	8	ChB-	Channel B negative, Sine 1Vpp
	9	ChZ-	Index channel negative, RS-422 input
	10	Clk-	Clock channel negative, RS-422 input
	11	EnIn0	TTL Level Input No. 0 (max 5VDC Input)
	12	EnIn1	TTL Level Input No. 1 (max 5VDC Input)
	13	EnIn2	TTL Level Input No. 2 (max 5VDC Input)
	14	EnIn3	TTL Level Input No. 3 (max 5VDC Input)
	15	Gnd	Signal Ground

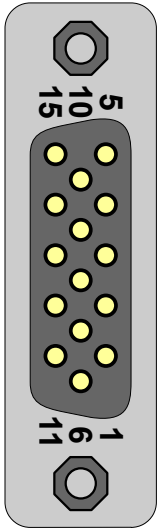

Table 1: Pin layout of the encoder connectors of the TAES encoder splitter. See also [1] for the pin layouts of different encoder types.

## 2. Connections inside the encoder splitter

A simplified schematic of the connections inside the encoder splitter is shown in Figure 2.

### 2.1. Encoder supply

The encoder supply from the drive is used to supply the encoder and the internals of the encoder splitter. This supply of the drive is not connected to the power line of drive split, leaving pin 1 of X3 floating.

### 2.2. Analog channels

The analog channel A (leads 2,7) and B (leads 3,8) are directly connected between encoder and drive. Each line is tapped at high impedance, amplified and fed differentially to the respective leads of drive split. This ensures minimal influence on the signal to the drive.

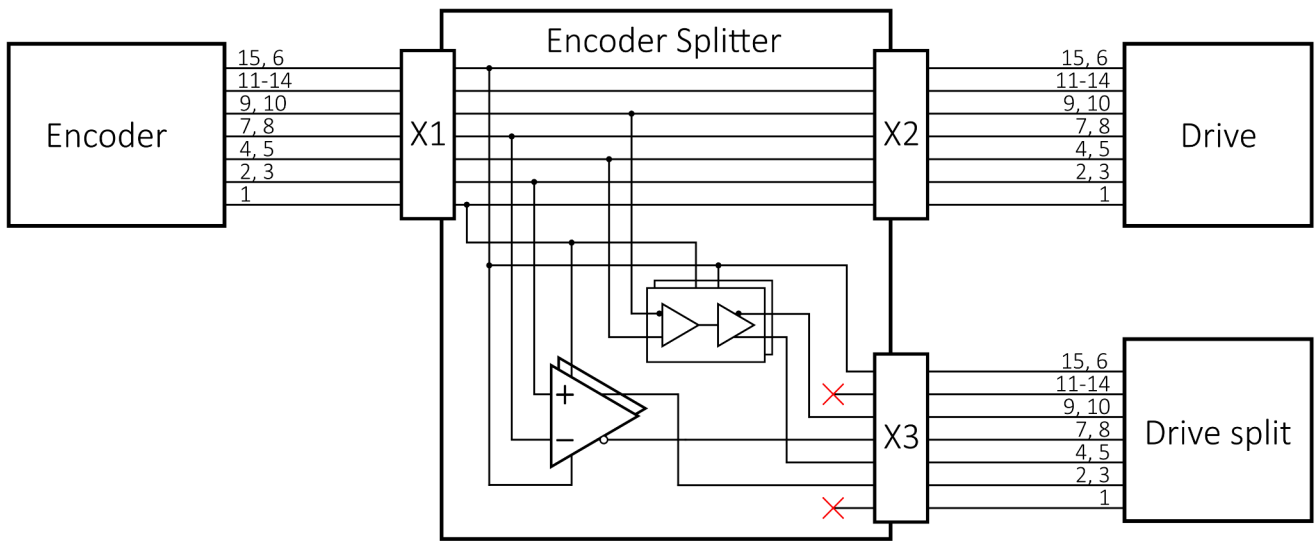

Figure 2: Schematic of the wiring inside the TAES encoder splitter.

### 2.3. Clock and Data channels

Analogously to the analog channels, the data (leads 4,9) and clock (leads 5, 10) channels are connected directly between encoder and drive. They are tapped at high impedance and fed differentially to the respective leads of drive split.

### 2.4. Digital TTL channels

The four TTL channels 11-14 are connected directly between encoder and drive. They are not connected to drive split, leaving the respective leads at X3 floating.

### 2.5. Ground

Signal and protective ground (lead 6 and 15) are connected to each other and the ground leads of both the drive and drive split.

### 3. Compatibility

The TAES encoder splitter is compatible with most encoder types. However, due to the tapping of the signals at high impedance, the connections to drive and drive split are not equivalent. Analog and incremental encoders, which only read from the encoder, are not obstructed in their function, such that drive and drive split work likewise. However, this prevents bidirectional data transfer to drive split for digital protocols. Additionally, the digital TTL signals are not fed to drive split. See also [1][2] for more information about the individual encoder types.

The following encoder types are supported:

- Analog sin/cos encoder with index
- Incremental RS422 and RS422 fast

The following encoder types are supported, with drive split able to receive, but not send data. In this case, no absolute position can be communicated with the split drive.

- Digital encoders with sin/cos signals (*Endat*, *BiSS-B*, *BiSS-C* protocols)

The following encoder type is not supported:

- Digital encoders without sin/cos signals (*EnDat*, *BiSS-B*, *BiSS-C*, *Tamagawa* and *Nikon* protocols)
- Incremental TTL Encoder with Index

### References

- [1] "Hardware Manual TSD80 / TSD130", HWTSD80-TSD130\_4-5\_HardwareManual\_EP015.pdf, Triamec Motion AG, 2024.
- [2] "Encoder Configuration", AN107\_Encoder\_EP024.pdf, Triamec Motion AG, 2024.



## Revision History

Version	Date	Editor	Comment
001	2024-04-04	yz, ab	Initial draft and review.
002	2026-02-16	fm	Update encoder support list