

Hardware Manual

TFD-C-350-15-50 Revision 1, TFS-C-700-40-50 Revision 1



Keep all manuals belonging to this product during its life span. Pass all manuals to future owners and users of this product. This English version is the original version of the product manual.

Former product name:

* TFC 700-40

Document HWTFX-C_HardwareManual_EP
Version 001, 2026-04-09
Source Q:\doc\Hardware\HWTF\TFX-C\Rev1\HardwareManual\
Destination T:\doc\Hardware
Owner chr

Table of Contents

- 1 General..... 3
 - 1.1 Target Group.....3
 - 1.2 Standards Used.....4
 - 1.3 Symbols Used.....4
- 2 Safety.....5
- 3 Technical Description.....6
 - 3.1 Product Specifications.....8
- 4 Nomenclature.....9
 - 4.1 Nameplate.....9
- 5 Handling and Installation.....10
 - 5.1 Transport.....10
 - 5.2 Storage.....10
 - 5.3 Ambient and Mounting Conditions.....11
 - 5.4 Mechanical Installation.....12
 - 5.4.1 Site.....12
 - 5.4.2 Cooling.....12
 - 5.4.3 Mounting.....12
 - 5.5 Electrical Installation.....13
 - 5.5.1 Electrical Connection to Motor and Servo Drive.....14
 - 5.5.2 Electrical Connection to the Fan.....15
 - 5.5.3 Connector to Filter Thermostat.....15
 - 5.6 Disassembling.....16
 - 5.7 Maintenance, Cleaning and Repair.....16
 - 5.7.1 Cleaning.....16
 - 5.7.2 Repair.....16
 - 5.8 Disposal.....16
- References.....17
- Revision History.....18

1 General

This manual provides information on the *Triamec Motion AG* motor-side filter models of the product families *TFS-C* (single-axis filters) and *TFD-C* (dual-axis filters). Filters of these product families contain a common-mode filter stage and can be used with all motor types. For motor-side filters that contain a common-mode and a differential-mode filter stage, refer to the manual of the *TFS-T* series.

The filter is installed between a high-speed servo drive and an electric motor. Common-mode filters are designed to prevent premature wear of bearings or tools due to electro-erosion caused by sparking, and for EMC-sensitive applications. For detailed information on the intended use of common-mode filters, refer to Chapter 3. In order to install your filter correctly and without problems, read this manual before carrying out any operation.

Technical data, dimensional drawings, and more information can be found at www.triamec.com.

1.1 Target Group

This manual addresses persons with the following qualifications:



Installation: Only electrically qualified personnel

1.2 Standards Used

Standard	Content
IEC 60364	Low-voltage electrical installations
IEC 60529:1989	Degrees of protection provided by enclosures (IP Code)
IEC 60664-1:2020	Insulation coordination for equipment within low-voltage systems
IEC 60721-3-2:2018 IEC 60721-3-3:2019	Classification of environmental conditions
EN 61800 EN 61800-1:2021 EN 61800-3:2022 EN 61800-5-1:2022	Adjustable speed electrical power drive systems General Requirements EMC requirements and specific test methods Safety requirements – Electrical, thermal and energy

1.3 Symbols Used







The following table lists the symbols that are used in this manual. Each symbol belongs to its danger class with the risk which arises when not complying the safety instruction.

Symbol	Indication
	DANGER CAUSED BY HIGH VOLTAGE OR HIGH CURRENT! Indicates an electrical hazard situation which will result in death or serious injury, if not avoided!
	DANGER CAUSED BY ROTATING OR MOVING PARTS! Indicates a hazard situation which could result in death or serious injury, if not avoided!
	ATTENTION! Indicates a hazard situation which could result in minor or moderate injury or may cause damage to or malfunction of the hardware, if not avoided!

Notice: Indicates useful information or a reference to another document

2 Safety

- Notice:** The user must have read and understood this manual before carrying out any operation on *Triamec* hardware. The safety information must be observed every time to avoid hazards and/or material damage. *Triamec Motion AG* disclaims all responsibility to possible industrial accidents and material damages if the procedures & safety instructions described in this manual are not followed.
- Notice:** Check the Hardware Revision Number of the product. This revision number must match the Hardware Revision Number on the cover page of this manual. Always comply with the connection conditions and technical specifications.
- Notice:** Please contact *Triamec Motion AG* in case of missing information or doubt regarding the installation procedures, safety or any other issue.

Safety Information	
	During operation there are hazards, with the possibility of death, serious injury or material damage. Do not open or touch the equipment during operation. Keep all covers and cabinet doors closed during operation. Touching the equipment is allowed during installation for properly qualified persons only.
	There is a danger of electrical arcing to electrical contacts or persons. To avoid electric arcing, never touch contacts of the filter or connect/disconnect the filter while the power source is on.
	The device contains capacitors that carry a high voltage. Power off the installation and wait at least ten minutes before disconnecting the filter . Before touching potentially live sections of the filter (e.g. contacts), the voltage between phases U/V/W and earth must be measured to verify it is below 40V.
	In case of machine failure or accident, do not touch any potentially live sections of the filter until verifying that they do not carry voltages above 40V.
	Only properly qualified personnel are permitted to carry out activities such as transport, installation, commissioning and maintenance. Properly qualified persons are those who are familiar with the transport, assembly, installation, commissioning and operation of the product, and who have the appropriate qualifications for their job. The qualified personnel must know and observe the following standards: <ul style="list-style-type: none"> • IEC 60364 and IEC 60664 • national accident prevention regulations
	The filter may have hot surfaces during operation and some time after disconnecting it from power. The surface can reach temperatures above 90°C. Touching the surface can lead to personal injury.

3 Technical Description

The output voltage of a servo drive is generated using pulse-width modulation (PWM), where the drive rapidly switches the voltages between the high and low levels of the DC-bus. This results in a waveform with sharp transitions at the PWM frequency.

The applied voltage is separated into differential-mode (DM) and common-mode (CM) components. The differential-mode voltage is the potential difference across the motor windings, determining the current flow and driving the motor. The common-mode voltage is the sum of the phase voltages and does not contribute to the motor operation. Due to the PWM switching, the common-mode voltage fluctuates within the range of the DC-bus voltage at the PWM frequency. Figure 1 illustrates the electrical system and exemplifies the applied voltage for a 3-level PWM that operates at 50 kHz.

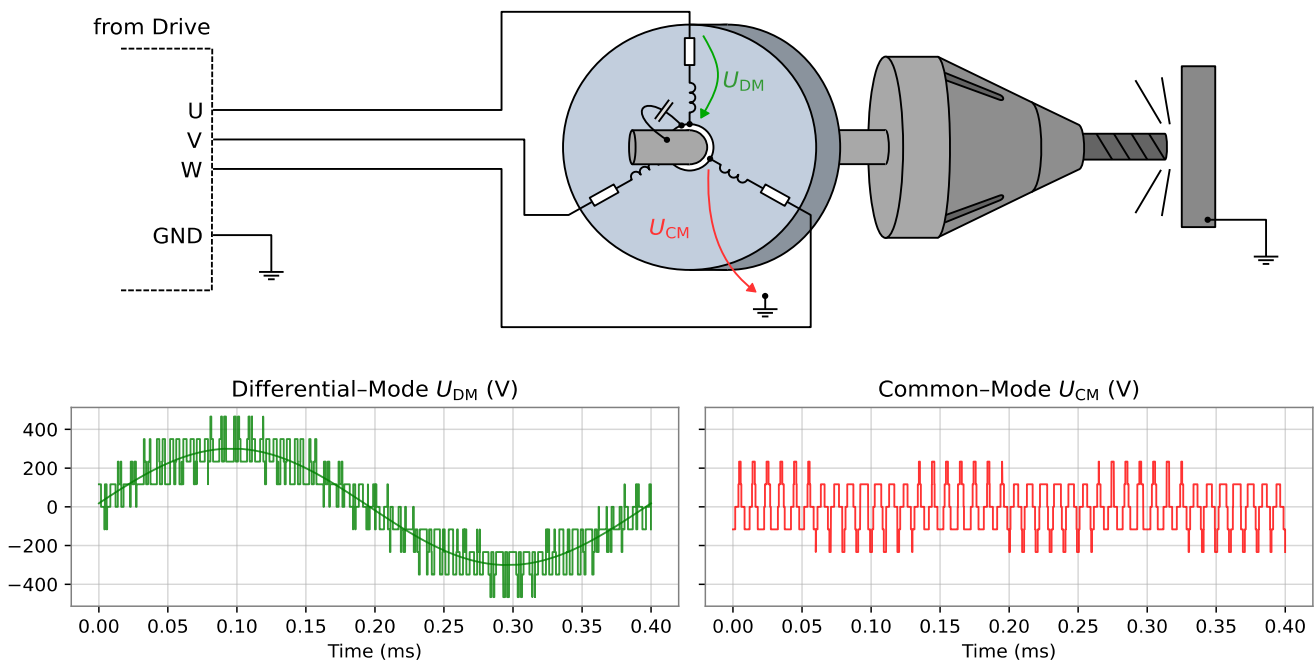

Figure 1: Schematic illustration of the electrical system and calculated time-series of the differential- and common-mode voltages for a typical application.

Under normal circumstances, the common-mode voltage does not lead to a significant current flow. However, when adding a capacitive path towards ground, unwanted electrical discharges can occur. A typical example is a spindle that is machining a grounded metallic workpiece (see Figure 2). The electrical arcing can damage motor bearings, tools and workpieces through electro-erosion, reducing equipment lifespan and machine accuracy.

Additionally, the rapid switching of the common-mode voltage generates electromagnetic interference (EMI), which may disrupt nearby electronics and lead to compliance challenges with EMC regulations. Minimizing EMI is critical to ensure stable operations of sensors, feedback systems, and communication interfaces.

Triamec Motion AG motor-side filters are designed to eliminate common-mode voltage fluctuations. The filter consists of two filter stages, as illustrated in Figure 2. The common-mode filter attenuates the common-mode voltage, which prevents electrical arcing and suppresses EMI. The second stage is a differential-mode filter, which mitigates the voltage spikes caused by PWM switching. This reduces the current ripple, which lowers the stress on motor windings and improves the overall system performance.

Triamec Motion AG filters of the *TFS-C* or *TFD-C* series feature a minimized differential-mode filter stage, making them suitable for all motor types. In contrast, filters of the *TFS-T* series are designed for low-inductance motors, such as spindle motors.

Notice: Caution is advised when using differential-mode filters from the *TFS-T* series in combination with high-inductance motors, as they may introduce resonances in the current control loop.

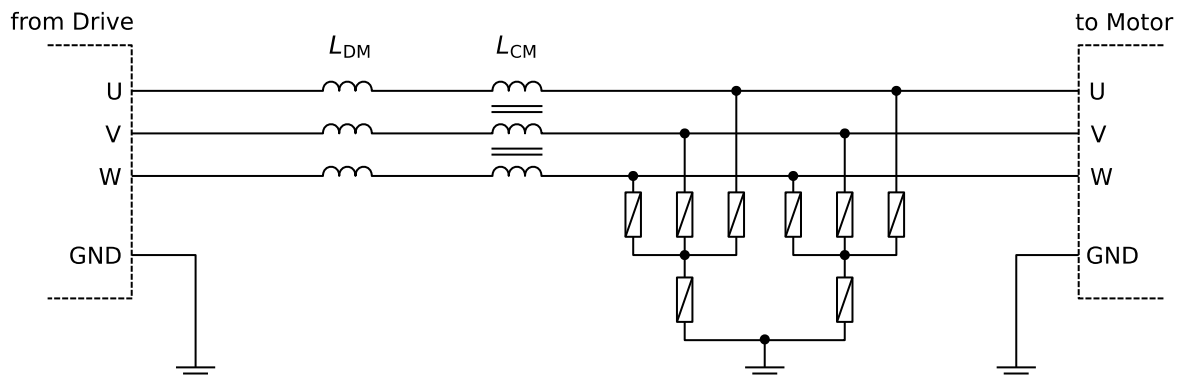

Figure 2: Technical design of the filter with differential-mode and common-mode filter stages.

3.1 Product Specifications

	TFD-C-350-15-50	TFS-C-700-40-50	Units
Axes	2	1	-
Max Voltage	350+10%	700+10%	V _{dc}
Continuous Current	15	40	A _{rms}
Min PWM Frequency	50	50	kHz
Dimensions W×H×D	69 × 279 × 303	149 × 310 × 419	mm
Weight	6.30	14.70	kg
Cooling	Fan to cool passive elements; 24V is required		-
Temperature Supervision	The filter is equipped with a thermostat triggering at <i>Thermostat Temp</i> ± 5°C. The state of the thermostat can be obtained externally using the provided pins (open when too hot). Apply max 24 V and 0.1 A.		-
Thermostat Temp	70		°C

Table 1: Specifications of the Triamec Motion AG motor-side filters addressed in this manual.

All available Triamec Motion AG products are listed on the website www.triamec.com.

4 Nomenclature

Product + Axes	-	Type	-	V _{DC}	-	A _{RMS}	-	min PWM freq (kHz)	[-	modifiers	-]
TFS	-	C	-	700	-	40	-	50			

Table 2: Example part number TFS-C-700-40-50, representing a single-axis common-mode filter, rated for 700 Vdc and 40 Arms nominal current, and suitable for PWM frequencies ≥ 50 kHz.

Choose from the following product variants when ordering a Triamec Motion AG motor-side filter (TF).

- Filters are available as single-axis (TFS) or dual-axis (TFD) models, depending on the variant.
- The type specifies the filter technique. This manual covers products that are designed for common-mode filtering (C).
- The second number (V_{DC}) refers to the nominal DC-bus voltage rating.
- The third number indicates the nominal current.
- The last number specifies the minimum PWM frequency for which the filter is designed.

All available products are listed on the website www.triamec.com.

4.1 Nameplate

The nameplate of the TFS-C-700-40-50 is shown below. A similar label is found on all filter models.

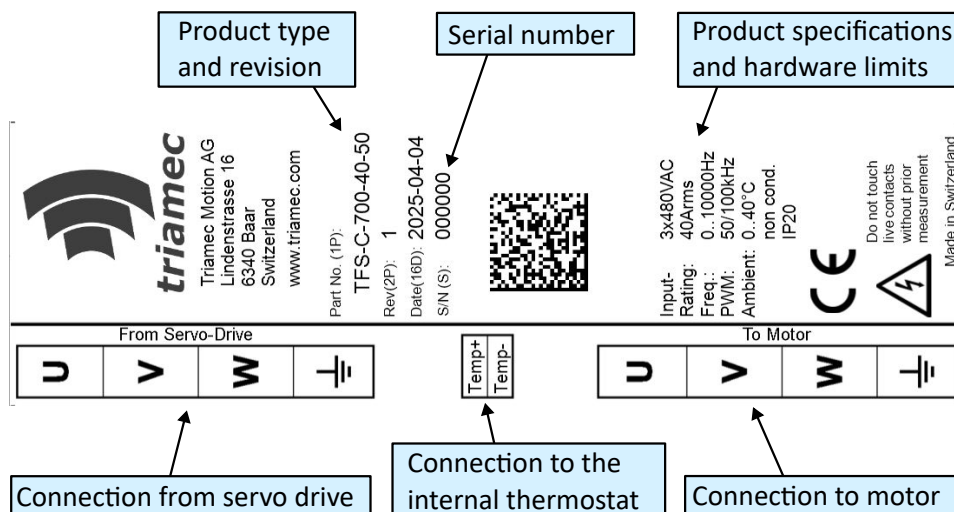

Figure 3: Label of the TFS-C-700-40-50 as an example for all labels of the Triamec Motion AG filter series.

5 Handling and Installation

5.1 Transport

- The transport conditions must respect the IEC 61800-1 standard.
- Transport by qualified personnel only.
- Avoid shocks while transporting.
- If the packaging is damaged, check the unit for visible damage. In such an event, inform the shipper and the manufacturer.

<i>TFD-C-350-15-50 / TFS-C-700-40-50</i>			
Temperature	-25°C (-13°F) and +70°C (+158°F), max. rate of change 20K / hour		
Humidity	less than 95% at max +40°C without condensation		
Shock limit	Dropping height of packed device max. 0.25m		
	Frequency	Amplitude	Acceleration
Vibration limit	2Hz ≤ f < 9Hz	3.5mm	not applicable
	9Hz ≤ f < 200Hz	not applicable	10m/s ²
	200Hz ≤ f < 500Hz	not applicable	15m/s ²

5.2 Storage

- The storage conditions must respect the IEC 61800-1 standard.

<i>TFD-C-350-15-50 / TFS-C-700-40-50</i>	
Temperature	-25°C (-13°F) and +55°C (+131°F), max. rate of change 20K / hour
Humidity	between 5 and 95% without condensation

5.3 Ambient and Mounting Conditions

<i>TFD-C-350-15-50 / TFS-C-700-40-50</i>	
Mounting Position	TFS-C-700-40-50: Vertical or horizontal TFD-C-350-15-50: Vertical (fans must be positioned at the bottom)
Ambient temperature in operation	According to IEC60721-3-3 class 3K3 +5°C (41°F) to +40°C (104°F), max. rate of change 20K / hour
Humidity in operation	5 to 85% without condensation
Cooling system	The unit has passive elements that heat up during operation. Care should be taken not to block the air inlets and outlets. Some filter models are equipped with a fan which is required for cooling. All filters are equipped with a thermostat (see specifications in 3.1) for external readout. No active over-temperature protection is provided.
Type of installation	Built-in unit, only for installation in a stationary control cabinet with minimal degree of protection IP4x.
Vibrations of system	The filter is intended for stationary use only and must not be installed in areas where they would be permanently exposed to vibrations. The mechanical conditions must respect the class 3M3 of the IEC 60721-3-2 standard.

5.4 Mechanical Installation

The following guidelines help to carry out the mechanical installation.

5.4.1 Site

- The filter should be mounted into a lockable control cabinet.
- The site must be free from conductive or corrosive materials.

5.4.2 Cooling

- The filter shall be spaced with a gap of 10 mm laterally.
- Do not cover air inlets and outlets with cables.
- The filter is equipped with a fan. Ensure sufficient clearance (≥ 25 mm) for proper airflow.

5.4.3 Mounting

- Assemble filters, servo drives and power supplies close together on the conductive, grounded mounting plate inside the cabinet.
- **TFS-C-700-40-50:** Install the filter in either a vertical or horizontal orientation.
TFD-C-350-15-50: Install the filter vertically, ensuring that the fans are positioned at the bottom.

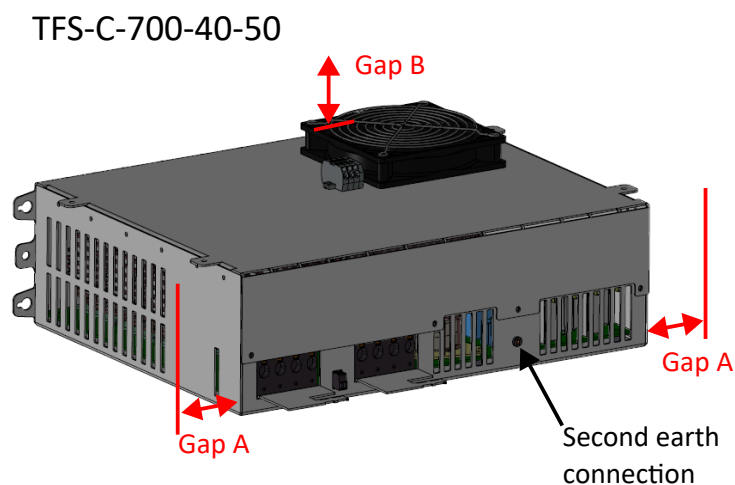



	<i>TFD-C-350-15-50</i>	<i>TFS-C-700-40-50</i>
Gap A	≥ 10 mm	≥ 10 mm
Gap B	≥ 25 mm	≥ 25 mm
Screws	2 × M4	4 × M4
Hole Spacing	252 mm	80 mm by 408 mm

Refer to the technical drawings at www.triamec.com for detailed specifications, including hole positions, screw sizes, and all necessary dimensions.

5.5 Electrical Installation

Follow these instructions for the electrical installation of the filter.

	Action
	1. Turn off the installation and disconnect the system from power. Follow the procedures and safety instructions of the corresponding devices. Disconnect the cabling between servo drive and motor if connected.
	2. Connect the casing to earth via the second earth connection point (M4). This is required by law.
	3. Connect the filter to the servo drive and the motor (see 5.5.1). Make sure that the cables are properly secured.
	4. Connect the 24V power supply to the fan power clamp (see 5.5.2).
	<i>Optional:</i> 5. If desired, connect the thermostat for overtemperature supervision
	5. Reconnect the installation to the power supply. The installation can now be turned on.

Notice: The filter influences the control loop of the system and **will require a retuning** of the servo drive.

5.5.1 Electrical Connection to Motor and Servo Drive

These connectors are used to connect the filter to the servo drive and to the motor. The cable must be shielded.

- Notice:** Make sure protective earth on connector and functional earth on shield are connected properly.
- Notice:** It is recommended to attach the motor shield directly to the electrical earth of the cabinet.
- Notice:** For more information regarding recommended grounding and shielding instructions, refer to Triamec Motion AG Application Note "Grounding Instructions" [1].

TFD-C-350-15-50					
From Drive:					
<i>Weidmüller, BVF 7.62HP/04/180MF4 BCF/06R SNBKBXSO Order-No.: 2486010000, 4 pins 7.62mm pitch & 4 pins)</i>					
To Motor:					
<i>Weidmüller, BVF 7.62HP/4/180MF4 BCF/6 SNBKBXSP180SO Order-No.: 2940440000, 4 pins 7.62mm pitch & 4 pins)</i>					
Pin Layout	Pin	Name	Description	Minimal Cross Section of Wire	Max Current
	1	W	Motor phase W	1.5 mm ²	15 Arms
	2	V	Motor phase V	1.5 mm ²	15 Arms
	3	U	Motor phase U	1.5 mm ²	15 Arms
	4	PE	Protective earth	Same or larger than UVW	
	5-8	Temp / Brake	Feedthrough for motor temperature input (pin 5 & 6) and brake output (pin 7 & 8).		

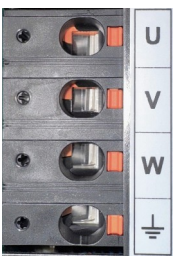
TFS-C-700-40-50					
<i>Cage clamp terminal</i>					
Pin Layout	Pin	Name	Description	Minimal Cross Section of Wire	Max Current
	1	U	Motor phase U	4.0 mm ²	40 Arms
	2	V	Motor phase V	4.0 mm ²	40 Arms
	3	W	Motor phase W	4.0 mm ²	40 Arms
	4	PE	Protective earth	Same or larger than UVW	

5.5.2 Electrical Connection to the Fan

The fan is connected to a 24 V DC power supply via the following pins.

TFD-C-350-15-50			
Pin Layout	Pin	Name	Description
	1	24V	DC power supply with 24V
	2	Gnd	Connection to Ground

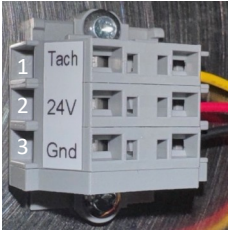
TFS-C-700-40-50			
Pin Layout	Pin	Name	Description
	1	Tach	Tachometer of the fan
	2	24V	DC power supply with 24V
	3	Gnd	Connection to Ground

5.5.3 Connector to Filter Thermostat



Connection to the filter thermostat triggering at $70 \pm 5^\circ\text{C}$. Thermostat is open when too hot.

Notice: Apply max 24 V and 0.1 A.

TFD-C-350-15-50 / TFS-C-700-40-50			
Pin Layout	Pin	Name	Description
	1	Temp +	Thermostat input terminal
	2	Temp -	Thermostat output terminal

5.6 Disassembling

Observe the sequence below to disconnect a filter from the installation (e.g. for replacement).

	Action
	1. Turn off the installation and wait at least ten minutes before disconnecting the filter to allow capacitors to discharge, as they may retain a high voltage. Before touching potentially live sections of the filter (e.g. contacts), the voltage between phases U/V/W and earth must be measured to verify it is below 40V.
	2. Disconnect the filter from servo drive and motor.
	3. Disconnect the fan.
	4. Disconnect the earth connection to the casing (M4).
	5. During operation, the filter casing may reach high temperatures. Before handling the device, check the temperature and wait until it has cooled below 40°C (104°F)

5.7 Maintenance, Cleaning and Repair

Notice: Opening the device voids warranty.

The device does not require any maintenance.

5.7.1 Cleaning

If the casing is dirty, clean with Isopropanol or similar. Do not immerse or spray. Dirt inside the unit must be cleaned by the manufacturer.

5.7.2 Repair

Repair of the filter must be done by the manufacturer. Disassemble the equipment as described in chapter 5.5.1 and send it in the original packaging to *Triamec Motion AG*.

5.8 Disposal

We take old devices and accessories back for professional disposal (WEEE-2002/96/EC-Guidelines). Transport costs are the responsibility of the sender. Disassemble the equipment as described in chapter 5.5.1 and send it to *Triamec Motion AG*.

References

The documents referenced in this manual

- [1] “Grounding Instructions”,
AN144_GroundingInstructions_EP002.pdf, Triamec Motion AG, 2022

